

**CITY OF COSTA MESA
PUBLIC WORKS AGREEMENT FOR
CITY PROJECT NO. 22-02**

THIS PUBLIC WORKS AGREEMENT ("Agreement"), dated November 15, 2022 ("Effective Date"), is made by the CITY OF COSTA MESA, a political subdivision of the State of California ("CITY"), and AMERICAN INTEGRATED SERVICES, California corporation a ("CONTRACTOR").

WHEREAS, CITY desires to construct the public improvements described below under Paragraph 1, Scope of Work (the "Project"); and

WHEREAS, CITY has determined that CONTRACTOR is the lowest responsible bidder; and

WHEREAS, CITY now desires to contract with CONTRACTOR to furnish construction and related services for the Project; and

WHEREAS, CITY and CONTRACTOR desire to set forth their rights, duties and liabilities in connection with the services to be performed.

NOW, THEREFORE, for and in consideration of the covenants and conditions contained herein, the parties hereby agree as follows:

1. SCOPE OF WORK.

The scope of work generally consists of providing environmental testing, utility investigation, structural assessment, reporting, plans, permitting, and construction required to safely close the existing 6,000 gallon City of Costa Mesa Police Department, Under Ground Storage Tank (UST).

The Police Department Underground Storage Tank Closure will be approached as an "abandon in place" project. Structural assessment and environmental testing may reveal unforeseen circumstances that could require additional remediation and/or the safe removal of the UST.

The initial project approach will be to abandon the underground storage tank, in place and the unit prices and bid schedule include the project scope as detailed in the 101-2.1 in the Special Provisions of the bid specifications (the "Work").

The Work is divided into two parts: the Investigatory Site Work and the Construction Site Work. Both parts of the Work are further described in the "Contract Documents" referred to below.

The Project is known as City Project No. 22-02 (the "Project").

2. CONTRACT DOCUMENTS.

The complete Agreement consists of the following documents relating to the Project:

- (a) This Agreement;
- (b) CONTRACTOR's bid is attached hereto as Exhibit A and incorporated herein;
- (c) The Bid Package along with Addendum One and Addendum Two to the Bid Package is attached hereto as Exhibit B and incorporated herein;
- (d) Faithful Performance Bond and Labor and Material Bond, including agent's Power of Attorney for each bond, attached hereto as Exhibit C;
- (e) Drug-Free Workplace Policy, attached hereto as Exhibit D and incorporated herein; and
- (f) Provisions of the most current edition of The Greenbook: Standard Specifications for Public Works Construction ("The Greenbook"). Provisions of The Greenbook are incorporated by this reference as if fully set forth herein.

The documents comprising the complete Agreement will be referred to as the "Contract Documents."

All of the Contract Documents are intended to complement one another, so that any Work called for in one and not mentioned in another is to be performed as if mentioned in all documents.

In the event of an inconsistency in the Contract Documents, the terms of this Agreement shall prevail over all other Contract Documents. The order of precedence between the remaining Contract Documents shall be as set forth in The Greenbook.

The Contract Documents constitute the entire agreement between the parties and supersede any and all other writings and oral negotiations.

3. CITY'S REPRESENTATIVE.

The CITY's Representative is Kian Nejad, referred to herein as the Project Manager ("Project Manager").

4. CONTRACTOR'S PROJECT MANAGER; PERSONNEL.

(a) Project Manager. CONTRACTOR's Project Manager must be approved by City. Such approval shall be at CITY's sole discretion.

(b) Personnel. CITY has the right to review and approve any personnel who are assigned to perform work under this Agreement. CONTRACTOR shall remove personnel from performing work under this Agreement if requested to do so by CITY.

This Paragraph 4 is a material provision of the Agreement.

5. SCHEDULE.

All Work shall be performed in accordance with the schedule approved on behalf of CITY by the Project Manager, and in accordance with the time of performance set forth in Paragraph 11 (Time of Performance).

6. EQUIPMENT - PERFORMANCE OF WORK.

CONTRACTOR shall furnish all tools, equipment, apparatus, facilities, labor and materials necessary to perform and complete the Work in a good and workmanlike manner in strict conformity with the Contract Documents.

The equipment, apparatus, facilities, labor and material shall be furnished and such Work performed and completed as required in the plans and specifications to the satisfaction of the Project Manager or his or her designee, and subject to his or her approval.

7. COMPENSATION.

CITY shall pay CONTRACTOR in accordance with the fee schedule set forth in CONTRACTOR's bid. CONTRACTOR's total compensation shall not exceed One-Hundred and Fifty-Six Thousand and Six-Hundred and Eighty Dollars (\$156,680.00).

8. ADDITIONAL SERVICES.

CONTRACTOR shall not receive compensation for any services provided outside the scope of the Contract Documents unless such additional services, including change orders, are approved in writing by CITY prior to CONTRACTOR performing the additional services.

It is specifically understood that oral requests or approvals of such additional services, change orders or additional compensation and any approvals from CITY shall be barred and are unenforceable.

9. PAYMENTS TO CONTRACTOR.

On or before the last Monday of each and every month during the performance of

the Work, CONTRACTOR shall meet with the Project Manager or his or her designee to determine the quantity of pay items incorporated into the improvement during that month. A "Progress Payment Order" will then be jointly prepared, approved, and signed by the Project Manager and the CONTRACTOR setting forth the amount to be paid and providing for a five percent (5%) retention. Upon approval of the progress payment order by the Project Manager, or his or her designee, it shall be submitted to CITY's Finance Department and processed for payment by obtaining approval from the City Council to issue a warrant.

Within three (3) days following City Council's approval to issue a warrant, CITY shall mail to CONTRACTOR a warrant for the amount specified in the progress payment order as the amount to be paid. The retained five percent (5%) shall be paid to CONTRACTOR thirty-five (35) days after the recording of the Notice of Completion of the Work by the CITY with the Orange County Clerk-Recorder and after CONTRACTOR has furnished releases of all claims against CITY by persons who furnished labor or materials for the Work, if required by CITY.

Upon the request of CONTRACTOR and at its expense, securities equivalent to the amount withheld pursuant to the foregoing provisions may be presented to CITY for substitution for the retained funds. If CITY approves the form and amount of the offered securities it will release the retained funds and will hold the securities in lieu thereof. CONTRACTOR shall be entitled to any interest earned on the securities.

In the event that claims for property damage or bodily injury are presented to CITY arising out of CONTRACTOR's or any subcontractor's work under this Agreement, CITY shall give notice thereof to CONTRACTOR, and CONTRACTOR shall have thirty-five (35) days from the mailing of any such notice to evaluate the claim and to settle it by whole or partial payment, or to reject it, and to give notice of settlement or rejection to CITY. If CITY does not receive notice within the above-mentioned 35-day period that the claim has been settled, and if the Project Manager, after consultation with the City Attorney, determines that the claim is meritorious, CITY may pay the claim or a portion of it in exchange for an appropriate release from the claimant, and may deduct the amount of the payment from the retained funds that would otherwise be paid to CONTRACTOR upon completion of the Work; provided, however, that the maximum amount paid for any one claim pursuant to this provision shall be One Thousand Dollars (\$1,000.00), and the maximum amount for all such claims in the aggregate paid pursuant to this provision shall be Five Thousand Dollars (\$5,000.00).

10. PROMPT PAYMENT OF SUBCONTRACTORS.

CONTRACTOR agrees to pay each subcontractor under this Agreement for satisfactory performance of its contract no later than seven (7) days from the receipt of each payment the CONTRACTOR receives from CITY.

CONTRACTOR agrees further to release retainage payments to each subcontractor within thirty (30) days after the subcontractor's work is satisfactorily

completed.

Any delay or postponement of payment from the above referenced time frame may occur only for good cause following written approval of the CITY.

11. TIME OF PERFORMANCE.

CONTRACTOR shall commence Investigatory Site Work by the date specified in CITY's Limited Notice to Proceed, unless a later date is agreed upon in writing by the parties. The Work under the Limited Notice to Proceed shall be completed within Ninety (90) calendar days from the first day of commencement of the Investigatory Site Work.

CONTRACTOR shall commence Construction Site Work by the date specified in the CITY's Notice to Proceed with Construction, unless a later date is agreed upon in writing by the parties. The Work under the Notice to Proceed with Construction shall be completed within Twenty-Five (25) working days from the first day of commencement of the Construction Site Work.

12. TERMINATION.

(a) Termination for Convenience. CITY may terminate this Agreement at any time, with or without cause, by providing thirty (30) days' written notice to CONTRACTOR.

(b) Termination for Breach of Contract.

(i) If CONTRACTOR refuses or fails to prosecute the Work or any severable part of it with such diligence as will ensure its timely completion, or if CONTRACTOR fails to complete the Work on time, or if CONTRACTOR, or any subcontractor, violates any of the provisions of the Contract Documents, the Project Manager may give written notice to CONTRACTOR and CONTRACTOR's sureties of the CITY's intention to terminate this Agreement; and, unless within five (5) days after the serving of that notice, such conduct shall cease and arrangements for the correction thereof be made to the satisfaction of the CITY, this Agreement may be terminated at the option of CITY effective upon CONTRACTOR's receipt of a second notice sent by the CITY indicating that the CITY has exercised its option to terminate.

(ii) If CONTRACTOR is adjudged bankrupt or files for any relief under the Federal Bankruptcy Code or State insolvency laws, this Agreement shall automatically terminate without any further action or notice by CITY.

(iii) If CONTRACTOR is in breach of any material provision of this Agreement, CITY may immediately terminate this Agreement by providing written notice to CONTRACTOR of same.

13. LIQUIDATED DAMAGES.

In the event the range upgrades scope of work or restroom improvements scope of work is not completed, for any reason, within the time required including any approved extensions of time, and to the satisfaction of the Project Manager, CITY may, in addition to any other remedies, equitable and legal, including remedies authorized by Paragraph 12 (Termination) of this Agreement, charge to CONTRACTOR or its sureties, or deduct from payments or credits due CONTRACTOR, a sum equal to Five Hundred and Twenty-Five Dollars (\$525.00) as liquidated damages for each calendar day beyond the date provided for the completion of such work.

The parties hereto agree that the amount set forth above, as liquidated damages constitutes a fair and reasonable estimate of the costs the CITY would suffer for each day that the CONTRACTOR fails to meet the performance schedule. The parties hereby agree and acknowledge that the delays in the performance schedule will cause CITY to incur costs and expenses not contemplated by this Agreement.

14. PERFORMANCE BY SURETIES.

In the event CONTRACTOR fails or refuses to perform the Work, CITY may provide CONTRACTOR with a notice of intent to terminate as provided in Paragraph 12 (Termination), of this Agreement. CITY shall immediately give written notice of such intent to terminate to CONTRACTOR and CONTRACTOR's surety or sureties, and the sureties shall have the right to take over and perform this Agreement; provided, however, that the sureties must, within five (5) days after CITY's giving notice of termination, (a) give the CITY written notice of their intention to take over the performance of this Agreement; (b) provide adequate assurances, to the satisfaction of the CITY, that the Work shall be performed diligently and in a timely manner; and (c) must commence performance thereof within five (5) days after providing notice to the CITY of their intention to take over the Work. Upon the failure of the sureties to comply with the provisions set forth above, CITY may take over the Work and complete it, at the expense of CONTRACTOR, and the CONTRACTOR and the sureties shall be liable to CITY for any excess costs or damages including those referred to in Paragraph 13 (Liquidated Damages), incurred by CITY. In such event, CITY may, without liability for so doing, take possession of such materials, equipment, tools, appliances, Contract Documents and other property belonging to CONTRACTOR as may be on the site of the Work and reasonably necessary therefor and may use them to complete the Work.

15. DISPUTES PERTAINING TO PAYMENT FOR WORK.

Should any dispute arise respecting whether any delay is excusable, or its duration, or the value of the Work done, or of any Work omitted, or of any extra Work which CONTRACTOR may be required to do, or respecting any payment to CONTRACTOR during the performance of this Agreement, such dispute shall be decided by the Project Manager, and his or her decisions shall be final and binding upon

CONTRACTOR and its sureties.

16. SUPERINTENDENCE BY CONTRACTOR.

At all times during performance of the Work, CONTRACTOR shall give personal superintendence or have a competent foreman or superintendent on the worksite, with authority to act for CONTRACTOR.

17. INSPECTION BY CITY.

CONTRACTOR shall at all times maintain proper facilities and provide safe access for inspection by CITY to all parts of the Work and to all shops on or off-site where the Work or portions of the Work, are in preparation. CITY shall have the right of access to the premises for inspection at all times. However, CITY shall, at all times, comply with CONTRACTOR's safety requirements on the job site.

18. CARE OF THE WORK AND OFF-SITE AUTHORIZATION.

CONTRACTOR warrants that it has examined the site of the Work and is familiar with its topography and condition, location of property lines, easements, building lines and other physical factors and limitations affecting the performance of this Agreement. CONTRACTOR, at CONTRACTOR's sole cost and expense, shall obtain any permission, and all approvals, licenses, or easements necessary for any operations conducted off the premises owned or controlled by CITY. CONTRACTOR shall be responsible for the proper care and protection of all materials delivered to the site or stored off-site and for the Work performed until completion and final inspection and acceptance by CITY. The risk, damage or destruction of materials delivered to the site or to Work performed shall be borne by CONTRACTOR.

19. CONTRACT SECURITY AND GUARANTEE.

CONTRACTOR shall furnish, concurrently with the execution of this Agreement, the following: (1) a surety bond in an amount equal to one hundred percent (100%) of the contract price as security for the faithful performance of this Agreement, and (2) a separate surety bond in an amount equal to at least one hundred percent (100%) of the contract price as security for the payment of all persons furnishing labor or materials in connection with the Work under this Agreement. Sureties for each of the bonds and the forms thereof shall be satisfactory to CITY. In addition, such sureties must be authorized to issue bonds in California; sureties must be listed on the latest revision to the U.S. Department of the Treasury Circular 570; and must be shown to have sufficient bonding capacity to provide the bonds required by the Contract Documents.

CONTRACTOR shall provide a certified copy of the certificate of authority of the surety issued by the Insurance Commissioner; a certificate from the clerk of the county in which the court or officer is located that the certificate of authority of the surety has not been surrendered, revoked, canceled, annulled, or suspended or, in the event that it has,

that renewed authority has been granted; and copies of the surety's most recent annual statement and quarterly statement filed with the Department of Insurance pursuant to Article 10 (commencing with Section 900) of Chapter 1 of Part 2 of Division 1 of the Insurance Code.

CONTRACTOR guarantees that all materials used in the Work and all labor performed shall be in conformity with the Contract Documents including, but not limited to, the standards and specifications set forth in the most current edition of The Greenbook. CONTRACTOR shall, at its own expense, make any and all repairs and replacements that shall become necessary as the result of any failure of the Work to conform to the aforementioned Contract Documents, and/or standard specifications; provided, however, that CONTRACTOR shall be obligated under this provision only to the extent of those failures or defects of which CONTRACTOR is given notice within a period of twelve (12) months from the date that the Notice of Completion is recorded.

The rights and remedies available to CITY pursuant to this provision shall be cumulative with all rights and remedies available to CITY pursuant to statutory and common law, which rights and remedies are hereby expressly reserved, and neither the foregoing guarantee by CONTRACTOR nor its furnishing of the bonds, nor acceptance thereof by CITY, shall constitute a waiver of any rights or remedies available to CITY against CONTRACTOR.

20. INDEMNIFICATION.

CONTRACTOR agrees to protect, defend, indemnify and hold harmless CITY and its elected and appointed boards, officers, agents, and employees from any and all claims, liabilities, expenses, or damages of any nature, including attorneys' fees, for injury to or death of any person, and for injury or damage to any property, including consequential damages of any nature resulting therefrom, arising out of or in any way connected with the performance of this Agreement. The defense obligation provided for hereunder shall apply without any advance showing of negligence or wrongdoing by the CONTRACTOR, its employees, and/or authorized subcontractors, but shall be required whenever any claim, action, complaint, or suit asserts as its basis the negligence, errors, omissions or misconduct of the CONTRACTOR, its employees, and/or authorized subcontractors, and/or whenever any claim, action, complaint or suit asserts liability against the CITY, its elected officials, officers, agents and employees based upon the work performed by the CONTRACTOR, its employees, and/or authorized subcontractors under this Agreement, whether or not the CONTRACTOR, its employees, and/or authorized subcontractors are specifically named or otherwise asserted to be liable. Notwithstanding the foregoing, the CONTRACTOR shall not be liable for the defense or indemnification of the CITY for claims, actions, complaints or suits arising out of the sole active negligence or willful misconduct of the CITY. This provision shall supersede and replace all other indemnity provisions contained either in the CITY's specifications or CONTRACTOR's proposal, which shall be of no force and effect.

CONTRACTOR shall comply with all of the provisions of the Workers'

Compensation insurance laws and Safety in Employment laws of the State of California, including the applicable provisions of Divisions 4 and 5 of the California Labor Code and all amendments thereto and regulations promulgated pursuant thereto, and all similar State, Federal or local laws applicable; and CONTRACTOR shall indemnify and hold harmless CITY from and against all claims, liabilities, expenses, damages, suits, actions, proceedings and judgments, of every nature and description, including attorney fees, that may be presented, brought or recovered against CITY for or on account of any liability under or failure to comply with any of said laws which may be incurred by reason of any Work performed under this Agreement by CONTRACTOR or any subcontractor or others performing on behalf of CONTRACTOR.

CITY does not, and shall not, waive any rights against CONTRACTOR which it may have by reason of the above hold harmless agreements, because of the acceptance by CITY or the deposit with CITY by CONTRACTOR of any or all of the insurance policies described in Paragraph 21 (Insurance) of this Agreement.

The hold harmless agreements by CONTRACTOR shall apply to all liabilities, expenses, claims, and damages of every kind (including but not limited to attorneys' fees) incurred or alleged to have been incurred, by reason of the operations of CONTRACTOR or any subcontractor or others performing on behalf of CONTRACTOR, whether or not such insurance policies are applicable. CONTRACTOR shall require any and all tiers of subcontractors to afford the same degree of indemnification to the CITY OF COSTA MESA and its elected and appointed boards, officers, agents, and employees that is required of CONTRACTOR and shall incorporate identical indemnity provisions in all contracts between CONTRACTOR and all tiers of its subcontractors.

In the event that CONTRACTOR and CITY are sued by a third party for damages caused or allegedly caused by negligent or other wrongful conduct of CONTRACTOR, or by a dangerous condition of CITY's property created by CONTRACTOR or existing while the property was under the control of CONTRACTOR, CONTRACTOR shall not be relieved of its indemnity obligation to CITY by any settlement with any such third party unless that settlement includes a full release and dismissal of all claims by the third party against the CITY.

21. INSURANCE.

(a) Minimum Scope and Limits of Insurance. CONTRACTOR shall not commence work under this Agreement until it has obtained all insurance required under this Paragraph 21 and CITY has approved the insurance as to form, amount, and carrier, nor shall CONTRACTOR allow any subcontractor to commence any Work until all similar insurance required of the subcontractor has been obtained and approved.

CONTRACTOR shall obtain, maintain, and keep in full force and effect during the life of this Agreement all of the following minimum scope of insurance coverages with an insurance company admitted to do business in California, rated "A," Class X, or better in the most recent Best's Key Insurance Rating Guide, and approved by CITY:

- (i) Commercial general liability, including premises-operations, products/completed operations, broad form property damage, blanket contractual liability, independent contractors, personal injury or bodily injury with a policy limit of not less than One Million Dollars (\$1,000,000.00) per occurrence. If such insurance contains a general aggregate limit, it shall apply separately to this Agreement or shall be twice the required occurrence limit.
 - (ii) Business automobile liability for owned vehicles, hired, and non-owned vehicles, with a policy limit of not less than One Million Dollars (\$1,000,000.00) combined single limit per accident for bodily injury and property damage.
 - (iii) Workers' compensation insurance as required by the State of California, with Statutory Limits, and Employer's Liability insurance with a limit of no less than One Million Dollars (\$1,000,000.00) per accident for bodily injury or disease. CONTRACTOR agrees to waive, and to obtain endorsements from its workers' compensation insurer waiving subrogation rights under its workers' compensation insurance policy against the CITY, its officers, agents, employees, and volunteers arising from work performed by CONTRACTOR for the CITY and to require each of its subcontractors, if any, to do likewise under their workers' compensation insurance policies.
 - (iv) Umbrella or excess liability insurance that will provide bodily injury, personal injury and property damage liability coverage at least as broad as the primary coverages set forth above, including commercial general liability, automobile liability, and employer's liability. Such policy or policies shall include the following terms and conditions:
 - (1) A drop down feature requiring the policy to respond in the event that any primary insurance that would otherwise have applied proves to be uncollectable in whole or in part for any reason;
 - (2) Pay on behalf of wording as opposed to reimbursement;
 - (3) Concurrency of effective dates with primary policies;
 - (4) Policies shall "follow form" to underlying primary policies; and
 - (5) Insureds under primary policies shall also be insureds under the umbrella or excess policies.
- (b) Endorsements. The commercial general liability insurance policy and business automobile liability policy shall contain or be endorsed to contain the following provisions:
- (i) Additional insureds: The City of Costa Mesa and its elected and appointed boards, officers, officials, agents, employees, and volunteers are additional insureds with respect to: liability arising out of activities performed by or on

behalf of the CONTRACTOR pursuant to its contract with the City; products and completed operations of the CONTRACTOR; premises owned, occupied or used by the CONTRACTOR; automobiles owned, leased, hired, or borrowed by the CONTRACTOR.”

- (ii) Notice: “Said policy shall not terminate, nor shall it be canceled nor the coverage reduced, until thirty (30) days after written notice is given to CITY.”
- (iii) Other Insurance: “CONTRACTOR’s insurance coverage shall be primary insurance as respects the City of Costa Mesa, its officers, officials, agents, employees, and volunteers. Any other insurance maintained by the City of Costa Mesa shall be excess and not contributing with the insurance provided by this policy.”

(c) Reporting Provisions. Any failure of CONTRACTOR to comply with the reporting provisions of the policies shall not affect coverage provided to the City of Costa Mesa, its officers, officials, agents, employees, and volunteers.

(d) Insurance Applies Separately. CONTRACTOR’s insurance shall apply separately to each insured against whom claim is made or suit is brought, except with respect to the limits of the insurer’s liability.

(e) Deductible or Self-Insured Retention. If any of such policies provide for a deductible or self-insured retention to provide such coverage, the amount of such deductible or self-insured retention shall be approved in advance by CITY. No policy of insurance issued as to which the CITY is an additional insured shall contain a provision which requires that no insured except the named insured can satisfy any such deductible or self-insured retention.

(f) Proof of Insurance. Prior to commencement of the Work, CONTRACTOR shall furnish CITY, through the Project Manager, proof of compliance with the above insurance requirements in a form satisfactory to City’s Risk Management.

(g) Non-Limiting. Nothing in this Paragraph 21 shall be construed as limiting in any way, the indemnification provision contained in this Agreement, or the extent to which Consultant may be held responsible for payments of damages to persons or property.

22. PREVAILING WAGE REQUIREMENTS.

(a) Prevailing Wage Laws. CONTRACTOR is aware of the requirements of Chapter 1 (beginning at Section 1720 et seq.) of Part 7 of Division 2 of the California Labor Code, as well as Title 8, Section 16000 et seq. of the California Code of Regulations (“Prevailing Wage Laws”), which require the payment of prevailing wage rates and the performance of other requirements on “public works” and “maintenance” projects. This Project is a “public works” project and requires compliance with the Prevailing Wage Laws. CONTRACTOR shall defend, indemnify and hold the CITY, its elected officials,

officers, employees and agents free and harmless from any claim or liability arising out of any failure or alleged failure to comply with the Prevailing Wage Laws.

(b) Payment of Prevailing Wages. CONTRACTOR shall pay the prevailing wage rates for all work performed under this Agreement. When any craft or classification is omitted from the general prevailing wage determinations, CONTRACTOR shall pay the wage rate of the craft or classification most closely related to the omitted classification. A copy of the general prevailing wage rate determination is on file in the Office of the City Clerk and is incorporated into this Agreement as if fully set forth herein. CONTRACTOR shall post a copy of such wage rates at all times at the project site(s).

(c) Legal Working Day. In accordance with the provisions of Labor Code Section 1810 et seq., eight (8) hours is the legal working day. CONTRACTOR and any subcontractor(s) of CONTRACTOR shall comply with the provisions of the Labor Code regarding eight (8)-hour work day and 40-hour work week requirements, and overtime, Saturday, Sunday, and holiday work. Work performed by CONTRACTOR's or any subcontractor's employees in excess of eight (8) hours per day, and 40 hours during any one week, must include compensation for all hours worked in excess of eight (8) hours per day, or 40 hours during any one week, at not less than one and one-half times the basic rate of pay. CONTRACTOR shall forfeit as a penalty to CITY Twenty-Five Dollars (\$25.00), or any greater penalty set forth in the Labor Code, for each worker employed in the execution of the Work by CONTRACTOR or by any subcontractor(s) of CONTRACTOR, for each calendar day during which such worker is required or permitted to the work more than eight (8) hours in one calendar day or more than 40 hours in any one calendar week in violation of the Labor Code.

(d) Apprentices. CONTRACTOR shall comply with the provisions of Labor Code Section 1777.5 concerning the employment of apprentices on public works projects. CONTRACTOR shall be responsible for ensuring compliance by its subcontractors with Labor Code Section 1777.5.

(e) Payroll Records. Pursuant to Labor Code Section 1776, CONTRACTOR and any subcontractor(s) shall keep accurate payroll records, showing the name, address, social security number, work classification, straight time and overtime hours worked each day and week, and the actual per diem wages paid to each journeyman, apprentice, worker, or other employee employed by CONTRACTOR or any subcontractor in connection with this Agreement. Each payroll record shall contain or be verified by a written declaration that it is made under penalty of perjury, stating both of the following: (1) The information contained in the payroll record is true and correct; and (2) The employer has complied with the requirements of Sections 1771, 1881, and 1815 of the Labor Code for any work performed by his or her employees on this Project. The payroll records shall be certified and shall be available for inspection at all reasonable hours in accordance with the requirements of Labor Code Section 1776. CONTRACTOR shall also furnish each week to CITY's Project Administration Division a statement with respect to the wages of each of its employees during the preceding weekly payroll period.

(f) Registration with DIR. CONTRACTOR and any subcontractor(s) of CONTRACTOR shall comply with the provisions of Labor Code Section 1771 and Labor Code Section 1725.5 requiring registration with the DIR.

23. COMPLIANCE WITH ALL LAWS.

CONTRACTOR shall, at its own cost and expense, comply with all applicable local, state, and federal laws, regulations, and requirements in the performance of this Agreement, including but not limited to laws regarding health and safety, labor and employment, and wage and hours.

24. DRUG-FREE WORKPLACE POLICY.

CONTRACTOR, upon notification of the award of this Agreement, shall establish a Drug-Free Awareness Program to inform employees of the dangers of drug abuse in the workplace, the penalties that may be imposed upon employees for drug abuse violations occurring in the workplace, and the employee assistance programs available to employees. Each employee engaged in the performance of a CITY contract must be notified of this Drug-Free Awareness Program, and must abide by its terms. CONTRACTOR shall conform to all the requirements of CITY's Policy No. 100-5, attached hereto. Failure to establish a program, notify employees, or inform the CITY of a drug-related workplace conviction will constitute a material breach of contract and cause for immediate termination of the contract by the CITY.

25. NON-DISCRIMINATION.

In performing this Agreement, CONTRACTOR will not engage in, nor permit its agents to engage in, discrimination in employment of persons because of their race, religion, color, national origin, ancestry, physical handicap, medical condition, marital status or sex, or sexual orientation, except as permitted pursuant to Section 12940 of the Government Code. Violation of this provision may result in the imposition of penalties referred to in Section 1735 of the California Labor Code.

26. PROVISIONS CUMULATIVE.

The provisions of this Agreement are cumulative and in addition to, and not in limitation of, any other rights or remedies available to CITY.

27. NOTICES.

It shall be the duty and responsibility of CONTRACTOR to notify all tiers of subcontractors and material men of the following special notice provision; namely, all preliminary 20-day notices or stop notices shall be directed only to the City Clerk and to no other department, and shall be either personally delivered or sent by certified mail, postage prepaid.

All other notices shall be in writing and delivered in person or sent by certified mail, postage prepaid. Notices required to be given to CITY pursuant to this Agreement shall be addressed as follows:

City of Costa Mesa
77 Fair Drive
Costa Mesa, CA 92626
Attn: Seung Yang

Notices required to be given to CONTRACTOR shall be addressed as follows:

American Integrated Services, Inc.
1502 E. Opp Street
Wilmington, CA 90744
Attn: John Georgagi

Notices required to be given to CONTRACTOR's sureties shall be addressed as follows:

U.S. Specialty Insurance Company
26001 McKenna Ct
Lake Forest, CA 92630
Attn: Les M. Mantle

28. INDEPENDENT CONTRACTOR.

The parties hereto acknowledge and agree that the relationship between CITY and CONTRACTOR is one of principal and independent contractor and no other. All personnel to be utilized by CONTRACTOR in the performance of this Agreement shall be employees of CONTRACTOR and not employees of the CITY. CONTRACTOR shall pay all salaries and wages, employer's social security taxes, unemployment insurance and similar taxes relating to employees and shall be responsible for all applicable withholding taxes. Nothing contained in this Agreement shall create or be construed as creating a partnership, joint venture, employment relations, or any other relationship except as set forth between the parties. The parties specifically acknowledge and agree that CONTRACTOR is not a partner with CITY, whether general or limited, and no activities of CITY or CONTRACTOR or statements made by CITY or CONTRACTOR shall be interpreted by any of the parties hereto as establishing any type of business relationship other than an independent contractor relationship.

29. PERS ELIGIBILITY INDEMNIFICATION.

In the event that CONTRACTOR or any employee, agent, or subcontractor of CONTRACTOR providing services under this Agreement claims or is determined by a court of competent jurisdiction or the California Public Employees' Retirement System (PERS) to be eligible for enrollment in PERS as an employee of the CITY,

CONTRACTOR shall indemnify, defend, and hold harmless CITY for the payment of any employee and/or employer contributions for PERS benefits on behalf of CONTRACTOR or its employees, agents, or subcontractors, as well as for the payment of any penalties and interest on such contributions, which would otherwise be the responsibility of CITY.

Notwithstanding any other agency, state or federal policy, rule, regulation, law or ordinance to the contrary, CONTRACTOR and any of its employees, agents, and subcontractors providing service under this Agreement shall not qualify for or become entitled to, and hereby agree to waive any claims to, any compensation, benefit, or any incident of employment by CITY, including but not limited to eligibility to enroll in PERS as an employee of CITY and entitlement to any contribution to be paid by CITY for employer contribution and/or employee contributions for PERS benefits.

30. VALIDITY.

The invalidity in whole or in part of any provision of this Agreement shall not void or affect the validity of any of the other provisions of this Agreement.

31. GOVERNING LAW.

This Agreement shall be governed by and construed in accordance with the laws of the State of California. Any legal action relating to or arising out of this Agreement shall be subject to the jurisdiction of the County of Orange, California.

32. NO THIRD PARTY BENEFICIARY RIGHTS.

This Agreement is entered into for the sole benefit of the CITY and CONTRACTOR and no other parties are intended to be direct or incidental beneficiaries of this Agreement and no third party shall have any right in, under or to this Agreement.

33. ASSIGNABILITY.

This Agreement may not be transferred or assigned by either party, or by operation of law, to any other person or persons or business entity, without the other party's written permission. Any such transfer or assignment, or attempted transfer or assignment, without written permission, may be deemed by the other party to constitute a voluntary termination of this Agreement and this Agreement shall thereafter be deemed terminated and void.

34. WAIVER.

No waiver of any provision of this Agreement shall be effective unless in writing and signed by a duly authorized representative of the party against whom enforcement of a waiver is sought referring expressly to this Paragraph. The waiver of any right or remedy in respect to any occurrence or event shall not be deemed a waiver of any right or remedy in respect to any other occurrence or event, nor shall any waiver constitute a

continuing waiver.

35. HEADINGS.

Section and subsection headings are not to be considered part of this Agreement, are included solely for convenience, and are not intended to modify or explain or to be a full or accurate description of the content thereof.

36. CONSTRUCTION.

The parties have participated jointly in the negotiation and drafting of this Agreement and have had an adequate opportunity to review each and every provision of the Agreement and submit the same to counsel or other consultants for review and comment. In the event an ambiguity or question of intent or interpretation arises with respect to this Agreement, this Agreement shall be construed as if drafted jointly by the parties and in accordance with its fair meaning. There shall be no presumption or burden of proof favoring or disfavoring any party by virtue of the authorship of any of the provisions of this Agreement.

37. COUNTERPARTS.

This Agreement may be executed in one or more counterparts by the parties hereto. All counterparts shall be construed together and shall constitute one Agreement.

38. CORPORATE AUTHORITY.

The persons executing this Agreement on behalf of the parties hereto warrant that they are duly authorized to execute this Agreement on behalf of said parties and that by doing so, the parties hereto are formally bound to the provisions of this Agreement.

[Signature page follows.]

IN WITNESS WHEREOF, the parties hereto have caused this Agreement to be executed by and through their respective authorized officers, as of the date first above written.

CITY OF COSTA MESA

A municipal corporation

Lori Ann Farrell Harrison
Lori Ann Farrell Harrison
City Manager

Date: 11/30/22

CONTRACTOR - American Integrated Services, Inc.

John Georgagi
Signature
John Georgagi, Executive Vice President
Name and Title

Date: 11/18/2022

ATTEST:

Brenda Green
Brenda Green
City Clerk



Date: 12/1/2022

APPROVED AS TO FORM:

Kimberly Hall Barlow
Kimberly Hall Barlow
City Attorney

Date: 11/30/22

APPROVED AS TO INSURANCE:

Ruth Wang
Ruth Wang
Risk Management

Date: 11/29/22

APPROVED AS TO PURCHASING:

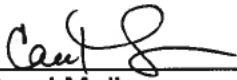

Carol Molina
Finance Director

Date: 11/29/22

DEPARTMENTAL APPROVAL:



Raja Sethuraman
Public Works Director

Date: 11-28-22

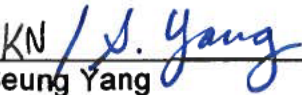

Seung Yang
Project Manager

Date: 11/28/2022

EXHIBIT A
CONTRACTOR'S BID

SECTION C

PROPOSAL FOR THE POLICE DEPARTMENT UNDERGROUND STORAGE TANK CLOSURE City Project No. 22-02

The Honorable City Council
City of Costa Mesa
77 Fair Drive
Costa Mesa, CA 92626

Dear Council Members:

In compliance with the NOTICE INVITING BIDS FOR THE **POLICE DEPARTMENT UNDERGROUND STORAGE TANK CLOSURE, CITY PROJECT NO. 22-02**, a copy which is hereto attached, the undersigned has carefully examined the location of the proposed Work, the Plans, Specifications and other Contract Documents and is therefore satisfied as to the conditions to be encountered, as to the character, quality and quantity of work to be performed and materials to be furnished and as to the requirements of the specifications and the Contract. It is mutually agreed that the submission of a proposal shall be considered prima facie evidence that the BIDDER has made such examination.

If awarded the Contract, the undersigned agrees to commence the Work under the Contract **WITHIN TEN (10) WORKING DAYS AFTER DATE OF CONTRACT, COMPLETE SAID INVESTIGATORY SITE WORK WITHIN NINETY (90) CALENDAR DAYS, AND COMPLETE SAID CONSTRUCTION SITE WORK WITHIN TWENTY-FIVE (25) WORKING DAYS** from the first day of commencement of such work unless legal extension is granted in accordance with the terms set forth in the specifications, and to perform and complete the Work in accordance with these Specifications and other Contract Documents, and to furnish all labor, materials, tools and equipment necessary to complete the Work in-place therefor, in the manner and time herein prescribed at the following prices, to wit:

BASE BID SCHEDULE PROPOSAL FOR UST ABANDONMENT

ITEM #	BID ITEM DESCRIPTION	EST. QTY.	UNIT	UNIT PRICE (in figures)	ITEMS TOTAL PRICE (in figures)
1	MOBILIZATION AND DEMOBILIZATION	1	LS	\$	\$18,256.00
INVESTIGATORY SITE WORK *					
2	PERMITTING	1	LS	\$	\$ 5,118.00
3	ENVIRONMENTAL COMPLIANCE	1	LS	\$	\$12,999.00
4	SITE INVESTIGATIONS AND UTILITY LOCATIONS	1	LS	\$	\$14,529.00
CONSTRUCTION SITE WORK **					
5	SITE PREP AND EXCAVATIONS	1	LS	\$	\$ 7,912.00
6	ABANDON TANK IN PLACE ***	1	LS	\$	\$18,105.00
7	BACKFILL	1	LS	\$	\$ 4,193.00
8	RESTORE SITE	1	LS	\$	\$ 5,568.00
9	ALLOWANCES	1	FA	\$70,000.00	\$70,000.00
* INVESTIGATORY SITE WORK TO BE COMPLETED IN 90 CALENDAR DAYS.					
** CONSTRUCTION SITE WORK TO BE COMPLETED IN 25 WORKING DAYS.					
*** BID ITEM MAY BE DELETED AND REPLACED FOR TANK REMOVAL, PER BID ITEM 9, AFTER INVESTIGATORY SITE WORK AS REQUIRED PER ENGINEER'S DIRECTION.					
Total Base Bid					\$156,680.00
TOTAL BASE BID PROPOSAL FIGURES:					\$156,680.00
TOTAL BASE BID PROPOSAL (Words): One Hundred Fifty-Six Thousand, Six Hundred Eighty Dollars					

The award of the Contract shall be based on the lowest responsive **Total Base Bid** amount, and the City reserves the right to delete one or to add more bid items and/or to increase and/or to decrease bid items' quantities.

The CITY also reserves the right to reject all Bids.

**PROPOSAL BID SCHEDULE
(CONTINUED)**

NOTES:

1. The accuracy of estimate quantities as shown is not guaranteed; the Bidder shall make his/her own estimate from the drawings and field review for verification. If the unit price and the total amount are different, the unit price will control the bid. Payment shall be based on actual work done and/or actual quantities used.
2. The City reserves the right to delete one or more bid items and/or to increase or decrease bid items' quantities, at no additional cost to the City.
3. FA designates force account. Payment shall be made on a time and materials basis, only if directed by the ENGINEER.
4. (F) Designates Final Pay Item. When an item of work is designated as "FINAL PAY ITEM" in the Specifications, the estimated quantity for that item of work shall be the final pay quantity, unless the dimensions of any portion of that item are revised by the Engineer, or the item or any portion of the item is eliminated. If the dimensions of any portion of the item are revised, and the revisions result in an increase or decrease in the estimated quantity of that item of work, the final pay quantity for the item will be revised in the amount represented by the changes in the dimensions. If a final pay item is eliminated, the estimated quantity for the item will be eliminated. If a portion of a final pay item is eliminated, the final pay quantity will be revised in the amount represented by the eliminated portion of the item of work.

The estimated quantity for each item of work designated as "FINAL PAY ITEM" in the Specifications, shall be considered as approximate only, and no guarantee is made that the quantity which can be determined by computations, based on the details and dimensions shown on the plans, will equal the estimated quantity. No allowance will be made in the event that the quantity based on computations does not equal the estimated quantity.

In case of discrepancy between the quantity shown in the Engineer's Estimate for a final pay item and the quantity or summation of quantities for the same item shown on the plans, payment will be based on the quantity shown in the Engineer's Estimate.

5. Bidder agrees to initial or notarize (if applicable) all pages on P-1, P-1a, P-1b, and P-2 thru P-11 and upload them onto *PlanetBids*.



Bidder's Initials
BID PROPOSAL

**PROPOSAL SCHEDULE
(CONTINUED)**

(Please Type or Print)

Total Amount for Bid (in written words) One Hundred Fifty-Six Thousand, Six Hundred Eighty Dollars (\$ 156,680.00)

Contractor's Lawful Name: American Integrated Services, Inc. in figures

Bidder's Name: John Georgagi Bidder's Initials: JG

Contractor's License No. 757133 Expiration: 12/31/2022

Contractor's Taxpayer I.D. Number: [REDACTED]

Contractor's DIR Registration Number: [REDACTED]

Signature: [Signature] Date: August 30, 2022

Contractor's Address: 1502 E Opp Street
Wilmington, CA 90744

Telephone Number: (310) 522-1168 Mobile No.: (562) 712-2759

Fax Number: (310) 522-0474 E-mail: jgeorgagi@americanintegrated.com

24-Hour Emergency Contacts:

24 Hour LIVE Answering Service Telephone Number [REDACTED]
Name

Hector Aguirre Telephone No.: [REDACTED]
Name

Name Telephone No.: ()
Mobile No.: ()

[Signature]
Bidder's Initials
PROPOSAL

PROPOSAL SCHEDULE**(CONTINUED)**

The Contractor agrees that the City will not be held responsible if any of the approximate quantities shown in the foregoing proposal shall be found incorrect, and he shall not make any claim for damages or for loss of profits because of a difference between the quantities of the various classes of work as estimated and the work actually done. If any error, omission or misstatements shall be discovered in the estimated quantities, it shall not invalidate this contract or release the Contractor from the execution and completion of the whole or part of the work herein specified, in accordance with the specifications and the plans herein mentioned and the prices herein agreed upon and fixed therefore, or excuse him from any of the obligations or liabilities hereunder, or entitle him to any damages or compensation otherwise than as provided for in this contract.

The Contractor agrees that the City shall have the right to increase or decrease the quantity of any bid item or portion of the work or to omit portions of the work as may be deemed necessary or expedient, and that the payment for incidental items or work, not separately provided in the proposal shall be considered included in the price bid for other various items or work.

Accompanying this proposal is "Cash," "Certified Check," or "Bidder's Bond" (circle one) in the amount of _____ ten percent (\$_____) equal to at least ten (10%) percent of the total bid price, payable to the City of Costa Mesa, to guarantee that within fourteen (14) days after written notice is deposited in the mail, or the bidder has received notice by telephone, the bidder will furnish proper Certificates of Insurance, and required bonds satisfactory to the City and execute a contract in accordance with the proposal and in the manner and form required by the contract documents.

The undersigned deposits the above-named security as a proposal guarantee and agrees that it shall be forfeited to the City of Costa Mesa as Liquidated Damages if the above requirements are not complied with.

Respectfully Submitted,

American Integrated Services, Inc.
 Contractor's Business Name
1502 E Opp Street
 Business Address: Street
Wilmington, CA 90744
 City State Zip
310-522-1168
 Business Phone Number

 Name Title

 City State Zip

John Georgagi Executive Vice President
 Contractor Title
[Signature]
 Signed By Title
757133 - A, B, HAZ - 12/31/2022
 Contractor's License No. and Classification Exp. Date
08/30/2022
 Date
6 Greenvale, Rancho Santa Margarita
 Residence: Street
562 712 2759
 Residence phone Number

If the bid is by a corporation, state the names of the officers who can sign an agreement on behalf of the corporation and whether more than one officer must sign.

Corporation

Taxpayer I.D. Number: 95-4698255

Name John Georgagi - Secretary
 Name P. David Herrera - President/Treasurer
 Name _____

Can Sign

Must Sign

If the bid is by a partnership or a joint venture, state the names and addresses of all general partners and joint ventures.

Partnership or Joint Ventures

Taxpayer I.D. Number: _____

Name _____
 Address _____
 Name _____
 Address _____

If the bidder is a sole proprietorship or another entity that does business under a fictitious name, the bid shall be in the real name of the bidder with a designation following showing "DBA (the fictitious name)"; provided, however, no fictitious name shall be used unless there is a current registration with the Orange County Recorder.

The full names and residences of all persons and parties interested in the foregoing proposal, as principals, are as follows:

NOTE: Give first and last names in full; in case of corporation, give names of President, Secretary, Treasurer and Manager, and affix corporate seal; in case of partnerships and joint ventures, give names of all the individual members.

P. David Herrera
John Georgagi

President/Treasurer
Secretary

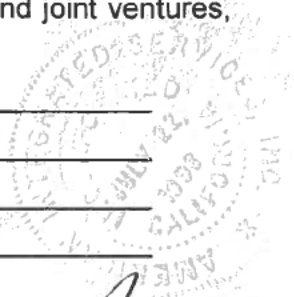

[Signature]
 Bidder's Initials

Bidder shall signify receipt of all Addenda here, if any:

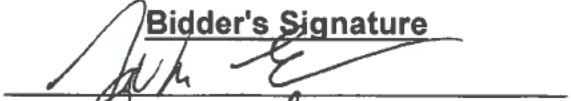
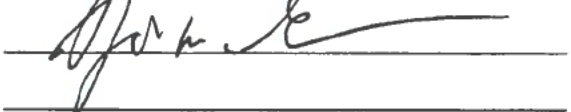
<u>Addendum No.</u>	<u>Date Received</u>	<u>Bidder's Signature</u>
1	08/16/2022	
2	08/17/2022	

CONSTRUCTION PROJECT REFERENCES

In order to more fully evaluate your firm's background and experience for the project herein proposed, it is requested that you submit a list of Public Works and/or similar construction projects completed, or in progress, within the last 24 months. This information will be used to evaluate whether the bid is responsive and or responsible to the call for bids.

<u>Date Project Awarded</u>	<u>Awarding Agency</u>	<u>Agency's Contract Administrator Contact Information</u>
07/29/2022	Citadel EHS - UST Removal, Burbank	Scott Grasse / sgrasse@citadelehs.com
07/11/2022	California Steel - Steel Tank Removal	JR Rivers / john.rivers@californiasteel.com
06/22/2022	Cardno - OCWD UST Removal, Anaheim	Sean Guiltinan / sean.guiltinan@cardno.com
06/13/2022	FH Associates - UST Removal, Glendora	dgelgur@ppd.ccoxmail.com
04/22/2022	Geosyntec - UST Removal, Culver City	Paige Farrell / pfarrell@geosyntec.com
02/28/2022	AECOM - Vons UST Removal, Lompoc	Jamalyn Green / jamalyn.green@aecom.com
10/20/2021	LBA Realty - UST Removal, West Sacto	Andrea Terwilliger / aterwilliger@lbarealty.com
10/19/2021	LBA Realty - UST Removal, West Sacto	Mark Kennedy / mkennedy@lbarealty.com
09/30/2021	Rincon - UST Removal, Los Angeles	Ryan Thacher / rthacher@rinconconsultants.com
08/01/2021	AECOM - UST Removal, Jamestown	Edmund Tarter / edmund.tarter@aecom.com
07/19/2021	DB Stephens - UST Removal, Los Angeles	John Dodge / jdodge@geo-logic.com
04/19/2021	Partner E&S - UST Removal, Azusa	Anthony Bottechia / abottechia@partneresi.com
04/05/2021	ERM - UST Removal, Los Angeles	John Estrada / john.estrada@erm.com
03/15/2021	Power 1 - Remove 4 UST, Universal City	Erick Castillo / ecastillo@power1ais.com
12/07/2020	Partner E&S - UST Removal, San Leandro	Joe Mangine / jmangine@partneresi.com

Bidder's Initials

DESIGNATION OF SUBCONTRACTORS

In compliance with the "Subletting and Subcontracting Fair Practices Act" being Sections 4100-4113 of the Public Contract Code of the State of California, and any amendments thereto, each bidder shall set forth below the name and location of the place of business of each subcontractor who will perform work or labor or render service to the prime contractor in or about the construction of the work or improvement in an amount in excess of one-half (½) of one percent (1%) of the prime contractor's total bid or in the case of bids for the construction of streets or highways, including bridges, in excess of one-half (½) of one percent (1%) of the prime contractor's total bid or ten thousand (\$10,000) dollars, whichever is greater. Bidder shall further set forth the portion of the work, which will be done by each such subcontractor with its Department of Industrial Relations (DIR) registration number. Only one subcontractor for each such portion shall be listed.

If the contractor fails to specify a subcontractor for any portion of the work to be performed under the contract, he/she/it shall be deemed to have agreed to perform the balance of all work, which is not covered, and he/she/it shall not be permitted to subcontract that portion of the work except under the conditions hereinafter set forth.

Subletting or subcontracting of any portion of the work to which no subcontractor was designated in the original bid, shall only be permitted in cases of public emergency or necessity, and then only after a finding reduced to writing as a public record of the Legislative Body of the Owner.

All information must be filled out and typed. Please use additional pages in this format if needed.

Bid Item (s) Number	% Portion of Work	Name, Address and E-mail of Subcontractor	State License Number	Class	DIR Registration Number
4	4.3%	Global Geo-Engineering, Inc. (consultant - soil characterization/investigation) 3 Corporate Park #270 Irvine, CA global@globalgeo.com	Geotech Eng #2301		N/A
			Civil Eng #41196		
3	2.5%	Ambient Environmental Inc. (consultant - soil sampling/closure report) 400 No Princeland Ct #3 Corona, CA 92879 tlane@ambient.com	N/A		N/A

By submission of this proposal, the Bidder certifies:

1. That (I)(we)(it) is able to and will perform the balance of all work which is not covered in the above subcontractors listing.

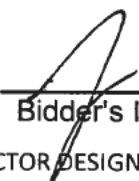
 Bidder's Initials
 SUBCONTRACTOR DESIGNATION

CITY OF COSTA MESA BIDDERS LIST

All bidders/proposers are required to provide the following information for all DBE and non-DBE subcontractors and suppliers, who provided a proposal, bid, quote, or were contacted by the proposed prime. This information is also required from the proposed prime contractor, and must be submitted with their bid/proposal. City of Costa Mesa will use this information to maintain and update a "Bidders List" to assist in evaluating the level of DBE participation on all Public Works projects. To the extent permitted by law, all information submitted will be held in confidence.

If Bidders List information is not submitted with the bid, it shall be submitted to the City of Costa Mesa, Construction Management Division, 77 Fair Drive, Costa Mesa, CA 92626, no later than 4:00 p.m. on the fourth day, not including Saturdays, Sundays and legal holidays, following the bid opening. Bidders List information sent by U.S. Postal Service certified mail with return receipt and certificate of mailing and mailed on or before the third day, not including Saturdays, Sundays and legal holidays, following bid opening will be accepted even if it is received after the fourth day following bid opening. Failure to submit the required Bidders List information by the time specified will be grounds for finding the bid or proposal non-responsive.

Firm Name: Global Geo-Engineering, Inc. Phone: 949-221-0900

Address: 3 Corporate Park, Ste 270 Fax: _____

Contact Person: Mohan B. Upasani No. of years in business: 21

Is the firm currently certified as a DBE under 49 CFR Part 26? YES NO

Type of work/services/materials provided by firm? Geotechnical Investigations

What was your firm's Gross Annual receipts for last year?

- Less than \$1 Million
- Less than \$5 Million
- Less than \$10 Million
- Less than \$15 Million
- More than \$15 Million

This form can be duplicated if necessary to report all bidders (DBE subcontractors, non-DBE subcontractors and/or suppliers' information).

M B Upasani
Bidder's Initials



CITY OF COSTA MESA BIDDERS LIST

All bidders/proposers are required to provide the following information for all DBE and non-DBE subcontractors and suppliers, who provided a proposal, bid, quote, or were contacted by the proposed prime. This information is also required from the proposed prime contractor, and must be submitted with their bid/proposal. City of Costa Mesa will use this information to maintain and update a "Bidders List" to assist in evaluating the level of DBE participation on all Public Works projects. To the extent permitted by law, all information submitted will be held in confidence.

If Bidders List information is not submitted with the bid, it shall be submitted to the City of Costa Mesa, Construction Management Division, 77 Fair Drive, Costa Mesa, CA 92626, no later than 4:00 p.m. on the fourth day, not including Saturdays, Sundays and legal holidays, following the bid opening. Bidders List information sent by U.S. Postal Service certified mail with return receipt and certificate of mailing and mailed on or before the third day, not including Saturdays, Sundays and legal holidays, following bid opening will be accepted even if it is received after the fourth day following bid opening. Failure to submit the required Bidders List information by the time specified will be grounds for finding the bid or proposal non-responsive.

Firm Name: Ambient ENV. INC Phone: 951-272-4730

Address: 400 N. Priscilla Ct. #3 Fax: W/A

Costa Mesa, CA 92679

Contact Person: Timothy Lane No. of years in business: 27

Is the firm currently certified as a DBE under 49 CFR Part 26? YES NO

Type of work/services/materials provided by firm? Environmental Compliance

What was your firm's Gross Annual receipts for last year?

- Less than \$1 Million
- Less than \$5 Million
- Less than \$10 Million
- Less than \$15 Million
- More than \$15 Million

This form can be duplicated if necessary to report all bidders (DBE subcontractors, non-DBE subcontractors and/or suppliers' information).

 Bidder's Initials
 BIDDERS LIST 

CITY OF COSTA MESA BIDDERS LIST

All bidders/proposers are required to provide the following information for all DBE and non-DBE subcontractors and suppliers, who provided a proposal, bid, quote, or were contacted by the proposed prime. This information is also required from the proposed prime contractor, and must be submitted with their bid/proposal. City of Costa Mesa will use this information to maintain and update a "Bidders List" to assist in evaluating the level of DBE participation on all Public Works projects. To the extent permitted by law, all information submitted will be held in confidence.

If Bidders List information is not submitted with the bid, it shall be submitted to the City of Costa Mesa, Construction Management Division, 77 Fair Drive, Costa Mesa, CA 92626, no later than 4:00 p.m. on the fourth day, not including Saturdays, Sundays and legal holidays, following the bid opening. Bidders List information sent by U.S. Postal Service certified mail with return receipt and certificate of mailing and mailed on or before the third day, not including Saturdays, Sundays and legal holidays, following bid opening will be accepted even if it is received after the fourth day following bid opening. Failure to submit the required Bidders List information by the time specified will be grounds for finding the bid or proposal non-responsive.

Firm Name: NANCY CARRAWAY Phone: 626 676 7681

Address: 991 EAST CALIFORNIA Boulevard
PASADENA, CALIFORNIA 91106 Fax: ---

Contact Person: NANCY CARRAWAY No. of years in business: 32

Is the firm currently certified as a DBE under 49 CFR Part 26? YES NO

Type of work/services/materials provided by firm? INDUSTRIAL HYGIENE,
CERTIFICATION OF TANKS TO BE SUITABLE FOR TRANSPORT

What was your firm's Gross Annual receipts for last year?

- Less than \$1 Million
- Less than \$5 Million
- Less than \$10 Million
- Less than \$15 Million
- More than \$15 Million

This form can be duplicated if necessary to report all bidders (DBE subcontractors, non-DBE subcontractors and/or suppliers' information).

Bidder's initials

COPY

Bond No. 305

Project and Specification No. 22-02

BIDDER'S BOND TO ACCOMPANY PROPOSAL

(Required if the bidder desires to submit bond instead of a certified or cashier's check.)

KNOW ALL PEOPLE BY THESE PRESENTS:

That we, American Integrated Services, Inc. as principals, and U.S. Specialty Insurance Company as surety, are held and firmly bound unto the City of Costa Mesa, a municipal corporation, organized under the laws of the State of California and situated in Orange County in the sum of TEN PERCENT OF THE AMOUNT OF THE BID (\$ 10% *****) to be paid to the City, its successors and assigns, for which payment well and truly to be made, we bind ourselves, our heirs, executors, and administrators, successors or assigns, jointly and severally firmly by these presents.

THE CONDITION OF THIS OBLIGATION IS SUCH,

That is the certain proposal of the above bounden, American Integrated Services, Inc., if accepted by the City of Costa Mesa, and if the above bounden, American Integrated Services, Inc., his heirs, executors, administrators, successors and assigns, shall duly enter into and execute a contract for such construction, and shall execute and deliver the CERTIFICATE OF INSURANCE and the LABOR AND MATERIAL and the FAITHFUL PERFORMANCE BONDS described within fourteen (14) days from the date of the mailing of a notice of the above bounden, American Integrated Services, Inc., by and from the City, that said contract is ready for execution, then this obligation shall become null and void; otherwise it shall be and remain in full force and virtue.

IN WITNESS WHEREOF:

We hereunto set our hands and seals this 18th day of August, 2022

American Integrated Services, Inc.

U.S. Specialty Insurance Company

By: [Signature]

By: [Signature]

John Georgagi-Vice President

Les M. Mantle-Attorney in Fact

Contractor/ Principal
(Notary Acknowledgement to be attached)

Surety/Power of Attorney
(Notary Acknowledgment to be attached)

[Signature]
Bidder's Initials

CALIFORNIA ALL-PURPOSE ACKNOWLEDGMENT

CIVIL CODE § 1189

A notary public or other officer completing this certificate verifies only the identity of the individual who signed the document to which this certificate is attached, and not the truthfulness, accuracy, or validity of that document.

State of California)
County of Los Angeles)
On August 22, 2022 before me, Lisa Ann Orr, Notary Public
Date Here Insert Name and Title of the Officer
personally appeared John Georgagi
Name(s) of Signer(s)

who proved to me on the basis of satisfactory evidence to be the person(s) whose name(s) is/are subscribed to the within instrument and acknowledged to me that he/she/they executed the same in his/her/their authorized capacity(ies), and that by his/her/their signature(s) on the instrument the person(s), or the entity upon behalf of which the person(s) acted, executed the instrument.

I certify under PENALTY OF PERJURY under the laws of the State of California that the foregoing paragraph is true and correct.

WITNESS my hand and official seal.

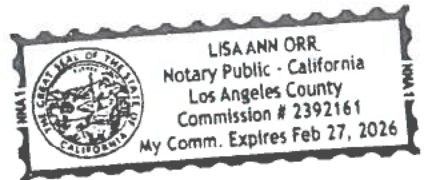

Signature Lisa Ann Orr
Signature of Notary Public

Place Notary Seal Above

OPTIONAL

Though this section is optional, completing this information can deter alteration of the document or fraudulent reattachment of this form to an unintended document.

Description of Attached Document

Title or Type of Document: _____
Document Date: _____ Number of Pages: _____
Signer(s) Other Than Named Above: _____

Capacity(ies) Claimed by Signer(s)

Signer's Name: _____
 Corporate Officer — Title(s): _____
 Partner — Limited General
 Individual Attorney in Fact
 Trustee Guardian or Conservator
 Other: _____
Signer Is Representing: _____

Signer's Name: _____
 Corporate Officer — Title(s): _____
 Partner — Limited General
 Individual Attorney in Fact
 Trustee Guardian or Conservator
 Other: _____
Signer Is Representing: _____

CALIFORNIA ACKNOWLEDGMENT

CIVIL CODE § 1189

A notary public or other officer completing this certificate verifies only the identity of the individual who signed the document to which this certificate is attached, and not the truthfulness, accuracy, or validity of that document.

State of California }
County of Orange }
On 8-18-2022 before me, Mary Martignoni - Notary Public
Date Here Insert Name and Title of the Officer
personally appeared Les M. Mantle
Name(s) of Signer(s)

who proved to me on the basis of satisfactory evidence to be the person(s) whose name(s) is/are subscribed to the within instrument and acknowledged to me that he/she/they executed the same in his/her/their authorized capacity(ies), and that by his/her/their signature(s) on the instrument the person(s), or the entity upon behalf of which the person(s) acted, executed the instrument.



I certify under PENALTY OF PERJURY under the laws of the State of California that the foregoing paragraph is true and correct.
WITNESS my hand and official seal.

Place Notary Seal and/or Stamp Above

Signature [Handwritten Signature]
Signature of Notary Public

OPTIONAL

Completing this information can deter alteration of the document or fraudulent reattachment of this form to an unintended document.

Description of Attached Document

Title or Type of Document: _____

Document Date: _____ Number of Pages: _____

Signer(s) Other Than Named Above: _____

Capacity(ies) Claimed by Signer(s)

Signer's Name: Les M. Mantle

- Corporate Officer – Title(s): _____
- Partner – Limited General
- Individual Attorney in Fact
- Trustee Guardian or Conservator
- Other: _____

Signer's Name: _____

- Corporate Officer – Title(s): _____
- Partner – Limited General
- Individual Attorney in Fact
- Trustee Guardian or Conservator
- Other: _____

Signer is Representing: _____

U.S. Specialty Insurance Company

Signer is Representing: _____



TOKIOMARINE
HCC

POWER OF ATTORNEY
AMERICAN CONTRACTORS INDEMNITY COMPANY TEXAS BONDING COMPANY
UNITED STATES SURETY COMPANY U.S. SPECIALTY INSURANCE COMPANY

KNOW ALL MEN BY THESE PRESENTS: That American Contractors Indemnity Company, a California corporation, Texas Bonding Company, an assumed name of American Contractors Indemnity Company, United States Surety Company, a Maryland corporation and U.S. Specialty Insurance Company, a Texas corporation (collectively, the "Companies"), do by these presents make, constitute and appoint

Les M. Mantle of Fullerton, California

its true and lawful Attorney(s)-in-fact, each in their separate capacity if more than one is named above, with full power and authority hereby conferred in its name, place and stead, to execute, acknowledge and deliver any and all bonds, recognizances, undertakings or other instruments or contracts of suretyship to include riders, amendments, and consents of surety, providing the bond penalty does not exceed *****Fifty Million***** Dollars (***\$50,000,000.00***). This Power of Attorney shall expire without further action on January 31st, 2024. This Power of Attorney is granted under and by authority of the following resolutions adopted by the Boards of Directors of the Companies:

Be it Resolved, that the President, any Vice-President, any Assistant Vice-President, any Secretary or any Assistant Secretary shall be and is hereby vested with full power and authority to appoint any one or more suitable persons as Attorney(s)-in-Fact to represent and act for and on behalf of the Company subject to the following provisions:

Attorney-in-Fact may be given full power and authority for and in the name of and on behalf of the Company, to execute, acknowledge and deliver, any and all bonds, recognizances, contracts, agreements or indemnity and other conditional or obligatory undertakings, including any and all consents for the release of retained percentages and/or final estimates on engineering and construction contracts, and any and all notices and documents canceling or terminating the Company's liability thereunder, and any such instruments so executed by any such Attorney-in-Fact shall be binding upon the Company as if signed by the President and sealed and effected by the Corporate Secretary.

Be it Resolved, that the signature of any authorized officer and seal of the Company heretofore or hereafter affixed to any power of attorney or any certificate relating thereto by facsimile, and any power of attorney or certificate bearing facsimile signature or facsimile seal shall be valid and binding upon the Company with respect to any bond or undertaking to which it is attached.

IN WITNESS WHEREOF, The Companies have caused this instrument to be signed and their corporate seals to be hereto affixed, this 23rd day of September, 2021.

AMERICAN CONTRACTORS INDEMNITY COMPANY TEXAS BONDING COMPANY
UNITED STATES SURETY COMPANY U.S. SPECIALTY INSURANCE COMPANY

State of California
County of Los Angeles



By: [Signature]
Daniel P. Aguilar, Vice President

A Notary Public or other officer completing this certificate verifies only the identity of the individual who signed the document to which this certificate is attached, and not the truthfulness, accuracy, or validity of that document.

On this 23rd day of September, 2021, before me, D. Littlefield, a notary public, personally appeared Daniel P. Aguilar, Vice President of American Contractors Indemnity Company, Texas Bonding Company, United States Surety Company and U.S. Specialty Insurance Company who proved to me on the basis of satisfactory evidence to be the person whose name is subscribed to the within instrument and acknowledged to me that he executed the same in his authorized capacity, and that by his signature on the instrument the person, or the entity upon behalf of which the person acted, executed the instrument.

I certify under PENALTY OF PERJURY under the laws of the State of California that the foregoing paragraph is true and correct.

WITNESS my hand and official seal.

Signature [Signature] (seal)



I, Kio Lo, Assistant Secretary of American Contractors Indemnity Company, Texas Bonding Company, United States Surety Company and U.S. Specialty Insurance Company, do hereby certify that the above and foregoing is a true and correct copy of a Power of Attorney, executed by said Companies, which is still in full force and effect; furthermore, the resolutions of the Boards of Directors, set out in the Power of Attorney are in full force and effect.

In Witness Whereof, I have hereunto set my hand and affixed the seals of said Companies at Los Angeles, California this 18th day of August, 2022

Corporate Seals
Bond No. 305
Agency No. 8227



[Signature]
Kio Lo, Assistant Secretary

Lisa Huizenga

From: TrackingUpdates@fedex.com
Sent: Tuesday, August 30, 2022 9:47 AM
To: Lisa Huizenga
Subject: FedEx Shipment 777788089068: Your package has been delivered



Hi. Your package was delivered Tue, 08/30/2022 at 9:37am.



Delivered to 77 FAIR DR, COSTA MESA, CA 92626
Received by A.AMY

OBTAIN PROOF OF DELIVERY

TRACKING NUMBER

777788089068

FROM

AMERICAN INTEGRATED SERVICES,
INC.

1502 E. Opp St

Wilmington, CA, US, 90744

TO

City Of Costa Mesa

Attn City Clerk

77 Fair Drive

COSTA MESA, CA, US, 92626

REFERENCE

Did-RFP 22-02

SHIPPER REFERENCE

Did-RFP 22-02

SHIP DATE

Mon 8/29/2022 04:18 PM

DELIVERED TO

Receptionist/Front Desk

PACKAGING TYPE

FedEx Envelope

ORIGIN

Wilmington, CA, US, 90744

DESTINATION

COSTA MESA, CA, US, 92626

SPECIAL HANDLING

Deliver Weekday

NUMBER OF PIECES

1

TOTAL SHIPMENT WEIGHT

0.50 LB

SERVICE TYPE

FedEx Priority Overnight

CONTRACT ASSURANCE

The CONTRACTOR or subcontractor shall not discriminate on the basis of race, color, national origin, or sex in the performance of this contract. The CONTRACTOR shall carry out applicable requirements of 49 CFR part 26 in the award and administration of DOT-assisted contracts. Failure by the CONTRACTOR to carry out these requirements is a material breach of this contract, which may result in the termination of this contract or such other remedy as recipient deems appropriate.

The CONTRACTOR will require that the above provision is included in all subcontracts.

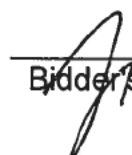
Bidder's Initials

NONCOLLUSION AFFIDAVIT

The bidders, by its officers and agents or representatives present at the time of filing this bid, being duly sworn on their oaths say, that neither they nor any of them have in any way directly or indirectly entered into any arrangement or agreement with any other bidder, or with any public officer of such CITY OF COSTA MESA whereby such affiant or affiants or either of them has paid or is to pay to such bidder or public officer any sum of money, or has given or is to give to such other bidder or public officer anything of value whatever, or such affiant or affiants or either of them has not directly or indirectly, entered into any arrangement or agreement with any other bidder or bidders, which tends to or does lessen or destroy free competition in the letting of the contract sought for on the attached bids; that no bid has been accepted from any subcontractor or supplier through any bid depository, the By-Laws, Rules, or Regulations of which prohibit or prevent the Contractor from considering any bid from any subcontractor or supplier which is not processed through said bid depository, or which prevent any subcontractor or supplier from bidding to any Contractor who does not use the facilities or accept bids from or through such bid depository; that bidder has not bid as subcontractor to other bidders; that no inducement of any form or character other than that which appears upon the face of the bid will be suggested, offered, paid or delivered to any person of the contract, nor has this bidder any agreement or understanding of any kind whatsoever, with any person whomsoever to pay, deliver to, or share with any other person in any way or manner, any of the proceeds of the contracts sought by this bid.

American Integrated Services, Inc.

Contractor Firm Name

John Georgagi

Name of Principal

Executive Vice President

Title

Signature

Subscribed and sworn to before me by:

John Georgagi

This 29th day of August, 2022

My Commission Expires: 02/27/2026

Lisa Orr
Notary Public

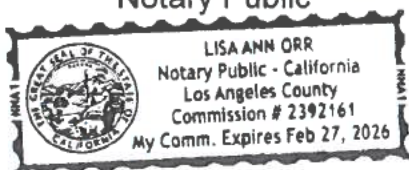

[Signature]
Bidder's Initials

**CONTRACTOR'S CERTIFICATION
OF
WORKERS' COMPENSATION INSURANCE REQUIREMENTS
FOR
PUBLIC WORKS PROJECTS
(Labor Code §1861)**

I am aware of the provisions of Section 3700 of the California Labor Code which requires every employer to be insured against liability for workers' compensation or to undertake self-insurance in accordance with the provisions of that Code, and I will comply with such provisions before commencing the performance of the work of this contract.

Dated: August 30, 2022

CONTRACTOR

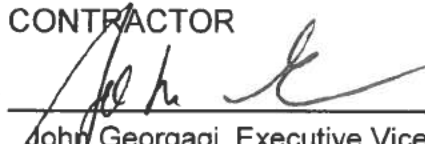

John Georgagi, Executive Vice President
American Integrated Services, Inc.

Company Name

PROJECT: POLICE DEPARTMENT UNDERGROUND STORAGE TANK CLOSURE,
CITY PROJECT NO. 22-02

Bidder's Initials

DRUG-FREE WORKPLACE POLICY

CONTRACTOR, upon notification of contract award, shall establish a Drug-Free Awareness Program to inform employees of the dangers of drug abuse in the workplace, the penalties that may be imposed upon employees for drug abuse violations occurring in the workplace, and the employee assistance programs available to employees. Each employee engaged in the performance of a CITY contract must be notified of this Drug-Free Awareness Program, and must abide by its terms. Failure to establish a program, notify employees, or inform CITY of a drug-related workplace conviction will constitute a material breach of contract and cause for immediate termination of the contract by CITY.

CONTRACTOR shall conform to all the requirements of CITY'S Policy No. 100-5. A copy of this policy is attached to the sample contract agreement as an attachment in the Project Specifications.

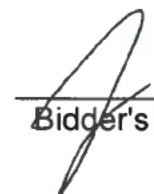
Bidder's Initials



**BIDDER/APPLICANT/CONTRACTOR
CAMPAIGN CONTRIBUTION DISCLOSURE FORM**

Proposer/Consultant/Applicant is required to identify any campaign contribution or cumulative contributions greater than \$249 to any city council member in the twelve months prior to submitting an application, proposal, statement of qualifications or bid requiring approval by the City Council.

Date	Name of Donor	Company/Business Affiliation	Name of Recipient	Amount
Nothing to report				

Except as described above, I/we have not made any campaign contribution in the amount of \$250 or more to any Costa Mesa City Council Member in the twelve months preceding this Application/Proposal.

I declare under penalty of perjury under the laws of the State of California that the foregoing is true and correct.



Bidder/Applicant/Proposer

August 30, 2022

Date



Bidder's Initials

EXHIBIT B
BID PACKAGE



CITY OF COSTA MESA

P.O. BOX 12000 77 FAIR DRIVE CALIFORNIA 92628-1200

FROM THE DEPARTMENT OF PUBLIC WORKS/ ENGINEERING DIVISION

DATE: August 11, 2022
TO: ALL PROSPECTIVE BIDDERS
SUBJECT: ADDENDUM NO. 1 – POLICE DEPARTMENT UNDERGROUND STORAGE TANK CLOSURE, CITY PROJECT NO. 22-02

Please forward this addendum to the appropriate individual as soon as possible. To assist our office in confirming the delivery of this addendum, please sign acknowledging receipt herein and e-mail a copy of this sheet to kian.nejad@costamesaca.com. **A COPY WILL NOT BE SENT BY MAIL.**

Received by: _____

Company: _____

All bidders shall register with PlanetBids.com in order to retrieve addenda. It is the responsibility of each prospective bidder to check the City's PlanetBids.com portal at: <https://www.planetbids.com/portal/portal.cfm?CompanyID=45476> on a DAILY basis through the close of bids for any applicable addenda or updates.

This addendum, effective on this date, addresses the following items:

MANDATORY		
<u>PRE-BID JOB WALK</u>	11:00 A.M., Wednesday, Aug 10, 2022	COMPLETED
<u>PRE BID JOB WALK LOCATION</u>	99 Fair Drive Costa Mesa, CA 92626	COMPLETED
<u>PRE-BID QUESTIONS</u>	5:00 P.M., Monday, Aug 22, 2022	NO CHANGE
<u>BID OPENING</u>	1:00 P.M., Tuesday, Aug 23, 2022	NO CHANGE

ADDENDUM 1 UPDATES:

1. As part of the base bid, Contractor shall disconnect and remove the Veeder-Root Box in the Police Department basement. The existing low power shall be capped in a covered electrical box. This work shall be considered part of **Bid Item No. 8 – Restore Site**. Please reference the pictures of the Veeder-Root box and its reports in **Attachment A1.1**.
2. As part of the base bid, Contractor shall remove and dispose all piping associated with the underground storage tank, and Contractor shall empty and cap all piping routed into the basement of Police Department building. This work shall be considered part of **Bid Item No. 6 – Abandon Tank In Place**. Please refer to the **Attachment A1.2** regarding the existing condition of the pipes in the Police Department basement.

Addendum No. 1
Project and Specifications No. 22-02

Please acknowledge receipt of Addendum 1 on the Proposal page "P-4"

Sincerely,

A handwritten signature in black ink, appearing to read "Kian Nejad". The signature is fluid and cursive, with a long, sweeping underline that extends to the right.

Kian Nejad
Associate Engineer

Attached and Posted to PlanetBids.com:

A1.1 – Photos of existing Veeder-Root Box and its reports. (2 Pages)

A1.2 – Existing underground storage tank piping in the basement (1 Page)

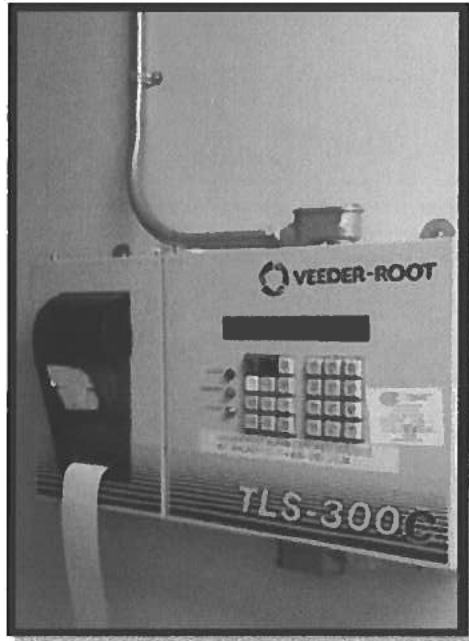

Figure A1.1.1 - As part of the base bid Contractor shall disconnect and remove the Veeder Root Box in the Police Department basement. Existing low power shall be capped in a covered electrical box.

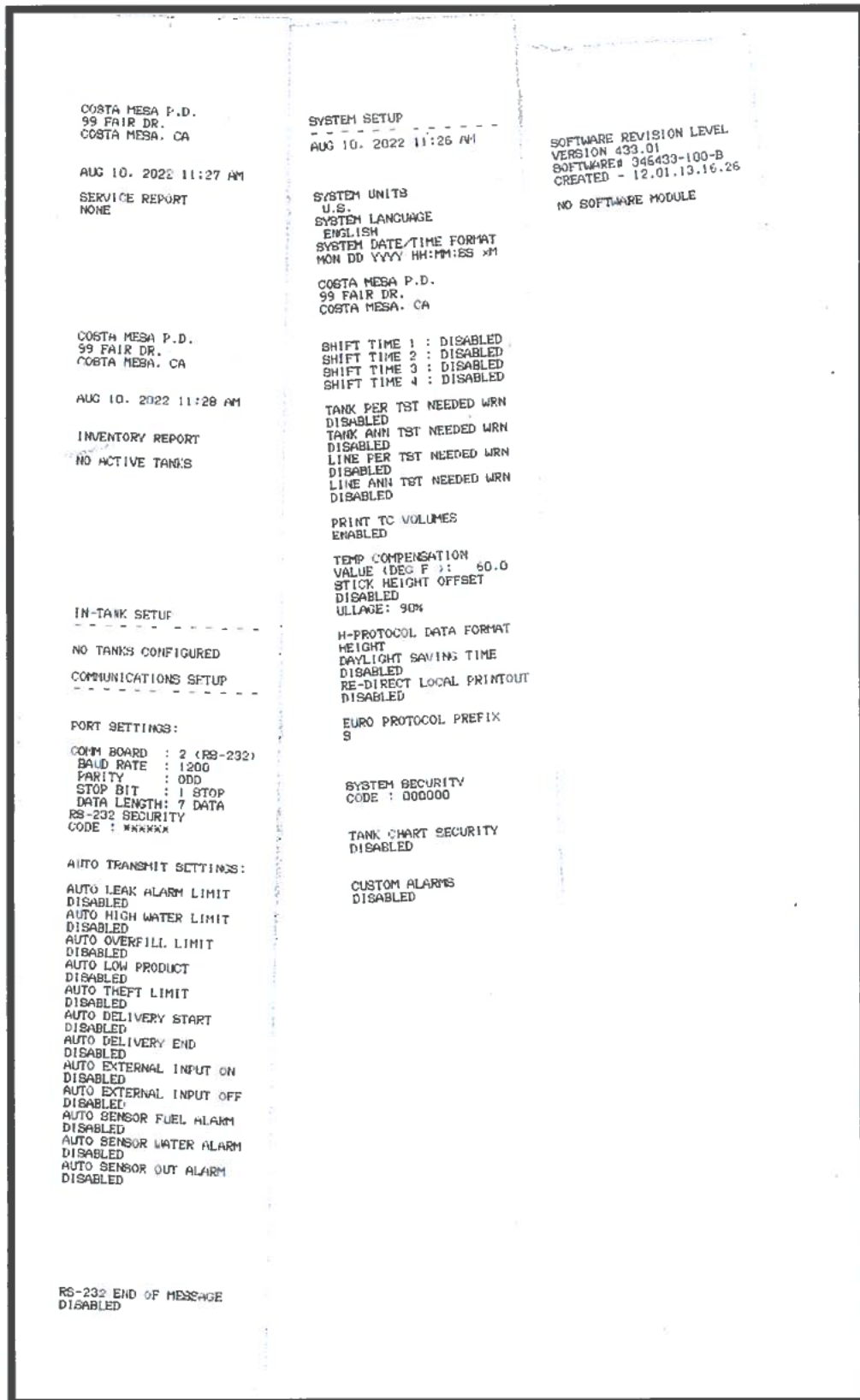

Figure A1.1.2 – Veeder-Root reports generated on August 10, 2022.

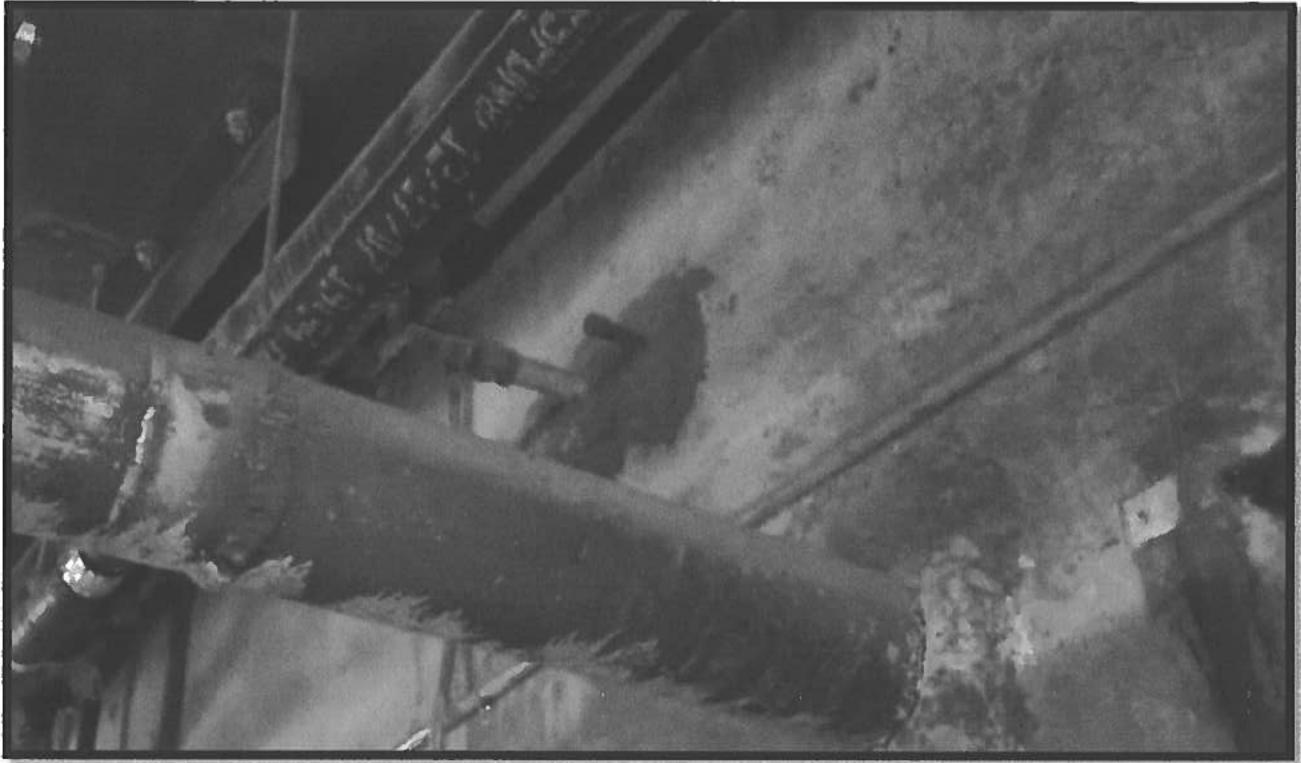

Figure A1.2.1 – Existing pipes from the tank have been capped and the holes patched inside the basement wall.



CITY OF COSTA MESA

P.O. BOX 12000 77 FAIR DRIVE CALIFORNIA 92628-1200

FROM THE DEPARTMENT OF PUBLIC WORKS/ ENGINEERING DIVISION

DATE: August 17, 2022

TO: ALL PROSPECTIVE BIDDERS

**SUBJECT: ADDENDUM NO. 2 – POLICE DEPARTMENT UNDERGROUND STORAGE
TANK CLOSURE, CITY PROJECT NO. 22-02**

Please forward this addendum to the appropriate individual as soon as possible. To assist our office in confirming the delivery of this addendum, please sign acknowledging receipt herein and e-mail a copy of this sheet to kian.nejad@costamesaca.com. **A COPY WILL NOT BE SENT BY MAIL.**

Received by: _____

Company: _____

All bidders shall register with PlanetBids.com in order to retrieve addenda. It is the responsibility of each prospective bidder to check the City's PlanetBids.com portal at: <https://www.planetbids.com/portal/portal.cfm?CompanyID=45476> on a DAILY basis through the close of bids for any applicable addenda or updates.

This addendum, effective on this date, addresses the following items:

MANDATORY PRE-BID JOB WALK	11:00 A.M., Wednesday, Aug 10, 2022	COMPLETED
PRE BID JOB WALK LOCATION	99 Fair Drive Costa Mesa, CA 92626	COMPLETED
PRE-BID QUESTIONS	5:00 P.M., Monday, Aug 22, 2022	NO CHANGE
BID OPENING	1:00 P.M., Tuesday, Aug 30, 2022	CORRECTED

SUMMARY ADDENDUM NO. 2:

1. Q&A responses to bidder's question posted on Planetbids.com:

SET 1 Question 1: On Planet bids and in the Specifications shows the bid date as August 30th 1pm but the addendum #1 shows it as August 23 at 1pm with no change. Can you please confirm the bid date.

Answer: The correct bid opening date is August 30th at 1pm.

Addendum No. 2
Project and Specifications No. 22-02

Please acknowledge receipt of Addendum 2 on the Proposal page "P-4"

Sincerely,

A handwritten signature in black ink, appearing to read "Kian Nejad", written in a cursive style.

Kian Nejad
Associate Engineer

CITY OF COSTA MESA
ORANGE COUNTY, CALIFORNIA

NOTICE TO BIDDERS, PROPOSAL, CONTRACT, AND
SPECIAL PROVISIONS FOR

**22-02 Police Department
Underground Storage Tank Closure**

Prepared Under the Direction of

Seung Yang, P.E.

City Engineer

Copy No. _____

Checked by _____

TABLE OF CONTENTS

	<u>PAGE NUMBER</u>
TABLE OF CONTENTS	i THRU vii
 SECTION A	
NOTICE INVITING BIDS	N-1 THRU N-3
 SECTION B	
INFORMATION FOR BIDDERS	B-1
1 PREPARATIONS OF BID FORM	B-1
2 QUALIFICATION OF BIDDERS	B-1
3 BID SECURITY	B-1
4 NON-COLLUSION AFFIDAVIT	B-1
5 SIGNATURE.....	B-1
6 CORRECTIONS	B-1
7 DELIVERY OF PROPOSAL	B-1
8 BID DEPOSIT RETURN.....	B-2
9 TAXES	B-2
10 WITHDRAWAL OF BIDS.....	B-2
11 AGREEMENT AND BONDS	B-2
12 FORFEITURE FOR FAILURE TO POST SECURITY AND EXECUTE AGREEMENT	B-2
13 BIDDERS INTERESTED IN MORE THAN ONE BID	B-2
14 EXAMINATION OF SITE AND CONTRACT DOCUMENTS.....	B-2
15 INTERPRETATION OF PLANS AND DOCUMENTS	B-2
16 ADDENDA	B-3
17 QUESTIONS TO THE ENGINEER	B-3
18 EQUIVALENT MATERIALS	B-3

**Table of Contents
(CONTINUED)**

	<u>PAGE NUMBER</u>
19 EVIDENCE OF RESPONSIBILITY.....	B-3
20 LEGAL RESPONSIBILITIES	B-3
21 ANTI-DISCRIMINATION	B-3
22 DRUG-FREE WORKPLACE POLICY.....	B-4
23 BID PROTEST PROCEDURES	B-4
24 ASSEMBLY BILL 626.....	B-4
REQUEST FOR INTERPRETATION OF CONTRACT DOCUMENTS	B-5

SECTION C

PROPOSAL.....	P-1 THRU P-11
----------------------	----------------------

SECTION D

PART 1 GENERAL PROVISIONS

SECTION 1 - GENERAL	GP-1
1-1 GENERAL	GP-1
ESTABLISHMENT OF STANDARD SPECIFICATIONS	
1-2 TERMS AND DEFINITIONS.....	GP-2
1-3 ABBREVIATIONS	GP-2
1-6 BIDDING AND SUBMISSION OF BID	GP-3
1-6.1.1 REQUEST FOR INTERPRETATION	GP-3
1-6.1.2 SOIL CONDITIONS	GP-4
1-6.1.3 RETURN OF BID SECURITY	GP-4
1-6.2 SUBCONTRACTING LISTING	GP-4
1-7 AWARD AND EXECUTION OF THE CONTRACT	GP-5
1-7.1.1 EXECUTION OF THE AGREEMENT	GP-5
1-7.2 CONTRACT BONDS.....	GP-5

Table of Contents
(CONTINUED)

	<u>PAGE NUMBER</u>
SECTION D CONTINUED	
SECTION 2 – SCOPE OF WORK	GP-6
2-1 WORK TO BE DONE	GP-6
2-2 PERMITS	GP-6
2-5 THE CONTRACTOR'S EQUIPMENT AND FACILITIES	GP-6
2-5.2 TEMPORARY UTILITY SERVICES	GP-6
2-5.4 HAUL ROUTES	GP-7
2-7 CHANGES INITIATED BY THE AGENCY	GP-7
2-8 EXTRA WORK	GP-8
2-9 CHANGED CONDITIONS	GP-8
SECTION 3 – CONTROL OF THE WORK	GP-9
3-1 ASSIGNMENT.....	GP-9
3-4 AUTHORITY OF THE BOARD AND THE ENGINEER	GP-9
3-5 INSPECTION	GP-10
3-6 THE CONTRACTOR'S REPRESENTATIVE	GP-10
3-7 CONTRACT DOCUMENTS	GP-11
3-10 SURVEYING.....	GP-11
3-10.3 LINE AND GRADE	GP-11
3-12 WORK SITE MAINTENANCE.....	GP-12
3-12.2 AIR POLLUTION CONTROL.....	GP-12
3-12.6 WATER POLLUTION CONTROL	GP-12
3-12.6.2 BEST MANAGEMENT PRACTICES (BMP's).....	GP-13
3-12.6.3 STORM WATER POLLUTION PREVENTION PLAN (SWPPP).....	GP-14
3-12.6.4 DEWATERING	GP-15
3-13.3 WARRANTY	GP-15

Table of Contents (CONTINUED)

SECTION D CONTINUED	<u>PAGE NUMBER</u>
SECTION 4 – CONTROL OF MATERIALS	GP-16
4-4 TESTING	GP-16
SECTION 5 – LEGAL RELATIONS AND RESPONSIBILITIES	GP-17
5-1 LAWS AND REGULATIONS	GP-17
5-2 SPECIAL NOTICES	GP-17
5-3 LABOR.....	GP-17
5-3.3 PAYROLL RECORDS	GP-17
5-3.5 APPRENTICES	GP-17
5-4 INSURANCE.....	GP-17
5-7 SAFETY	GP-18
5-7.1 WORK SITE SAFETY	GP-18
5-7.8 STEEL PLATE COVERS	GP-18
SECTION 6 – PROSECUTION AND PROGRESS OF THE WORK	GP-19
6-1 CONSTRUCTION SCHEDULE AND COMMENCEMENT OF THE WORK.....	GP-19
6-1.1 CONSTRUCTION SCHEDULE	GP-19
6-1.3 DAILY REPORT SUBMITTAL	GP-19
6-3 TIME OF COMPLETION	GP-19
6-5 USE OF IMPROVEMENT DURING CONSTRUCTION	GP-20
6-7 TERMINATION OF THE CONTRACT FOR DEFAULT	GP-20
6-7.3 NOTICE OF TERMINATION FOR DEFAULT	GP-20
6-7.4 RESPONSIBILITY OF SURETY.....	GP-20
6-9 LIQUIDATED DAMAGES	GP-20

Table of Contents (CONTINUED)

	<u>PAGE NUMBER</u>
SECTION D CONTINUED	
SECTION 7 – MEASUREMENT AND PAYMENT	GP-21
7-3 PAYMENT	GP-21
7-3.2 PARTIAL AND FINAL PAYMENT	GP-21
7-3.2.1 PROMPT PROGRESS PAYMENT TO SUBCONTRACTORS	GP-23
7-3.2.2 PROMPT PAY MONITORING AND ENFORCEMENT OF PROGRESS PAYMENTS	GP-23
7-3.3 DELIVERED MATERIALS	GP-24
7-3.4 MOBILIZATION	GP-24
7-3.4.1 TRAVEL ROUTE AND TRUCKING AN EQUIPMENT	GP-25
7-3.4.2 CONSTRUCTION SEQUENCE/ORDER OF WORK	GP-25
7-4 PAYMENT FOR EXTRA WORK	GP-25
7-4.2 BASIS FOR ESTABLISHING COSTS	GP-25
7-4.2.1 LABOR	GP-25
7-4.3 MARKUPS	GP-26
7-4.3.1 WORK BY THE CONTRACTOR	GP-26
7-4.3.2 WORK BY A SUBCONTRACTOR	GP-26
7-6 SUMMARY OF PUBLIC CONTRACT CODE § 9204	GP-26
SECTION E	
PART 1.1 – SPECIAL PROVISIONS	
101-1 GENERAL	SP-1
101-2 POLICE DEPARTMENT UNDERGROUND STORAGE TANK CLOSURE	SP-2
101-3 ALLOWANCES – ADDITIONAL WORK ITEMS	SP-8

Table of Contents (CONTINUED)

	<u>PAGE NUMBER</u>
SECTION F	
MODIFICATIONS TO STANDARD SPECIFICATIONS	
PART 2 – CONSTRUCTION MATERIALS (NO ADDITIONS OR MODIFICATIONS)	
PART 3 – CONSTRUCTION METHODS (NO ADDITIONS OR MODIFICATIONS)	
PART 4 – EXISTING IMPROVEMENTS	
SECTION 400 – PROTECTION AND RESTORATION	SS-1
400-1 GENERAL	SS-1
400-1.1 DRAINAGE CONTROL: RESPONSIBILITIES	SS-1
400-1.2 DRAINAGE CONTROL: EXCAVATION DEWATERING REQUIREMENTS.....	SS-1
SECTION 402 – UTILITIES	SS -2
402-1 LOCATION	SS -2
402-1.1 GENERAL	SS -2
402-1.2 PAYMENT	SS -3
402-2 PROTECTION	SS -3
402-2.1 PAYMENT	SS -3
402-4 RELOCATION	SS -4
PART 5 – PIPELINE SYSTEM REHABILITATION (NO ADDITIONS OR MODIFICATIONS)	
PART 6 – TEMPORARY TRAFFIC CONTROL	
SECTION 600 – ACCESS	SS-7
600-1 GENERAL	SS-7
600-1.1 NOTIFICATION AND ACCESS.....	SS-7
PART 7 – STREET LIGHTING AND TRAFFIC SIGNAL SYSTEMS(NO ADDITIONS OR MODIFICATIONS)	
PART 8 – LANDSCAPING AND IRRIGATION (NO ADDITIONS OR MODIFICATIONS)	

Table of Contents
(CONTINUED)

PAGE NUMBER

SECTION G

APPENDIX “A1”

DRAFT PROCEDURE FOR CLOSURE IN PLACE OF AN UNDERGROUND TANK 3 PAGES

APPENDIX “A2”

GUIDELINES FOR THE REMOVAL OF UNDERGROUND TANKS..... 3 PAGES

APPENDIX “A3”

OPERATING PERMIT FOR UST..... 10 PAGES

LOCATION MAPS FOR UST... .. 1 PAGE

APPENDIX “A4”

UTILITIES PLAN C2.0..... 1 PAGE

EXISTING BUILDING STRUCTURAL PLAN S2.1..... 1 PAGE

EXISTING BUILDING CIVIL PLAN S2.2... .. 1 PAGE

EXISTING BUILDING CIVIL PLAN S2.3... .. 1 PAGE

MISCELLANEOUS CONTRACT DOCUMENTS (SAMPLE)

1 AGREEMENT (SAMPLE)..... 21 PAGES

2 COUNCIL POLICY (D-1, D-2, D-3) 3 PAGES

3 LABOR AND MATERIAL PAYMENT BOND (SAMPLE)..... 1 PAGE

3 FAITHFUL PERFORMANCE BOND (SAMPLE)..... 1 PAGE

4 INSURANCE (SAMPLE) 6 PAGES

5 PERMIT APPLICATION FOR BUILDING 2 PAGES

6 PERMIT APPLICATION FOR PUBLIC SERVICES..... 1 PAGE

7 APPLICATION FOR BUSINESS LICENSE 1 PAGE

8 W-9 REQUEST FOR TAXPAYER ID NUMBER 4 PAGES

SECTION A

CITY OF COSTA MESA
ORANGE COUNTY, CALIFORNIA
NOTICE INVITING BIDS

NOTICE IS HEREBY GIVEN that the City of Costa Mesa ("City") invites sealed bids, to be submitted electronically only, for the following project:

**POLICE DEPARTMENT UNDERGROUND STORAGE TANK CLOSURE
CITY PROJECT NO. 22-02**

1. **BID SUBMISSION AND OPENING:** Bids must be submitted electronically via the City of Costa Mesa's PlanetBids portal before the deadline of **August 30, 2022 at 1:00 p.m.** at which time or shortly thereafter the City Clerk will open bids electronically. The bid results will be posted online via PlanetBids. No paper bids or any other form of submittal will be accepted. Any bid received after the scheduled closing time for the receipt of bids will be rejected. The City is not responsible for and accepts no liability in the event a response is late due to any network, internet, or any other technical difficulty or interruption. It shall be the sole responsibility of the bidder to ensure that his/her/its bid is received by the deadline.

To access the bid documents and bid on this project, potential vendors and bidders must first register through the City's PlanetBids portal at:

<https://www.planetbids.com/portal/portal.cfm?CompanyID=45476>.

2. **SCOPE OF WORK AND BID DOCUMENTS:** The scope of work generally consists of providing environmental testing, utility investigation, structural assessment, reporting, plans, permitting, and construction required to safely close the existing 6,000 gallon, City of Costa Mesa Police Department, Under Ground Storage Tank (UST).

The Police Department Underground Storage Tank Closure will be approached as an "abandon in place" project. Structural assessment and environmental testing may reveal unforeseen circumstances that could require additional remediation and/or the safe removal of the UST.

The plans, specifications, and bid documents for this project can be obtained via the City's PlanetBids portal at: <https://www.planetbids.com/portal/portal.cfm?CompanyID=45476>.

Questions regarding the bid documents will be received by the Engineer up to five (5) working days prior to the bid opening, deadline is **August 22, 2022 at 5:00 p.m.** Questions asked of the Engineer less than (5) working days prior to Bid Opening Date, may not be addressed.

It is the bidder's responsibility to ensure that the most current version of the solicitation, including any addenda, has been downloaded. Bids received without the applicable addenda will be rejected as incomplete.

3. **PRE-BID MEETING OR JOB WALK:** A mandatory pre-bid job walk has been scheduled for **August 10, 2022 at 11:00 a.m. at the project site. Located at 99 Fair Drive along the Westside of the Costa Mesa Police Department building on Vanguard Way at Fair Drive.**
4. **BID CONTENTS:** All bids must be submitted on the proposal form included in the bid documents. No bid will be considered unless it is made on the proposal form furnished by the City and made in accordance with the provisions of the bid requirements.

5. **BID SECURITY**: Each bidder must submit a certified check, cashier's check, or a bid bond, made payable to or in favor of the City of Costa Mesa, in an amount equal to at least ten percent (10%) of the total amount of the bid, to the Costa Mesa City Clerk prior to the bid submission deadline. No bid will be considered unless such certified check, cashier's check, or bid bond is received by the City Clerk prior to the bid submission deadline.
6. **CONTRACTOR'S LICENSE**: A valid **California Contractor's Class "A" General Engineering Contractors License and HAZ - Hazardous Substance Removal Certification License** issued by the California Contractors State License Board is required at the time the contract is awarded pursuant to California Public Contract Code section 3300. Each bidder must also be qualified as required by law at the time of the bid opening.
7. **REGISTRATION WITH THE DEPARTMENT OF INDUSTRIAL RELATIONS**: Pursuant to Labor Code sections 1725.5 and 1771.1, no contractor or subcontractor shall be qualified to bid on, be listed in a bid proposal, subject to the requirements of Section 4104 of the Public Contract Code, or engage in the performance of any contract for public work unless registered and qualified pursuant to Labor Code section 1725.5.
8. **PREVAILING WAGES**: This project is a "public work" subject to prevailing wage requirements. Pursuant to provisions of Sections 1770 et seq. of the California Labor Code, all works employed on the project shall be paid not less than the general prevailing rate of per diem wages, as determined by the Director of the Department of Industrial Relations (DIR) for work of a similar character in the locality in which the work is performed, and not less than the general prevailing rate of per diem wages for holiday and overtime work. Copies of the prevailing rate of per diem wages are on file with Costa Mesa Public Services Department and are available to any interested party upon request. The applicable State prevailing wages are also set forth on the Department of Industrial Relations' website: <http://www.dir.ca.gov>; these rates are subject to predetermined increases. The prime contractor shall post a copy of the DIR's determination of the prevailing rate of per diem wages at each job site. This project is subject to compliance monitoring and enforcement by the DIR.
9. **PAYMENT BOND AND PERFORMANCE BOND**: A Payment Bond and a Performance Bond, each in the amount of 100% of the contract amount, will be required of the successful bidder prior to award of the contract.
10. **RETENTION**: The City withholds five percent (5%) of each progress payment as retention. Pursuant to Public Contract Code section 22300, the successful bidder may substitute certain securities for money withheld by the City to ensure performance of the contract. At the request and expense of the contractor, securities equivalent to the amount withheld shall be deposited with the public agency, or with a state or federally chartered bank in this state as the escrow agent, who shall then pay those moneys to the contractor. Securities will be returned to the contractor upon satisfactory completion of the contract.
11. **NON-DISCRIMINATION**: The bidding process and contract are subject to State and Federal non-discrimination requirements, including but not limited to the requirement that no person or business shall discriminate on the basis of race, color, national origin, ancestry, religious creed, physical disability, mental disability, medical condition, marital status, sex, gender, gender expression, gender identity, sexual orientation, age, or military or veteran status in its solicitation, selection, hiring, or treatment of individuals or businesses in connection with the bidding process or work performed for the City in connection with the project.
12. **CITY'S RIGHT TO REJECT BIDS**: The City of Costa Mesa reserves the right, in its sole discretion, to reject any or all bids, or to waive any minor irregularities or informalities in any bid.

13. **ADDITIONAL REQUIREMENTS:** This project is subject to local, State, and Federal regulations and requirements, as detailed in the bid documents.

For all inquiries, please contact Associate Engineer: Kian Nejad, Public Works Department, via e-mail at KIAN.NEJAD@COSTAMESACA.GOV.

Brenda Green, City Clerk
City of Costa Mesa
Dated: July 27, 2022

SECTION B

INFORMATION FOR BIDDERS

1. PREPARATION OF BID FORM: The City of Costa Mesa (City) requires that bids be submitted on the proposal available on *PlanetBids* at such time and place as is stated in the Notice Inviting Bids. All information requested in the bid forms must be provided. All bids shall be submitted electronically via the City's public bidding platform, *PlanetBids* **only**. No other form of submittal shall be accepted. It is the sole responsibility of the Bidder to see that his bid is received in proper time. Any bid received after the scheduled closing time for receipt of bids will be **rejected**. Each Bidder is responsible for acknowledging all addenda and ensuring completed proposal forms are uploaded to the PlanetBids.com website. Bid information in the uploaded, electronically submitted proposal shall match the information that is manually populated into the PlanetBids.com website. Only bid information provided as part of the uploaded proposal will be considered part of the bid.
2. QUALIFICATION OF BIDDERS: Each Bidder shall submit a list of Construction Project References indicating Public Works and/or similar construction projects that include Underground Storage Tank abandonment and/or Underground Storage Tank removal activities which have been completed or in progress within the last 24 months. Forms for this purpose are furnished with the bid package.
3. BID SECURITY / BID BOND: Each bid shall be accompanied by one of the following: cash, cashier's check made payable to the City, a certified check made payable to the City, or a Bidder's Bond executed by an admitted surety insurer, made payable to the City, in an amount not less than 10% of the maximum amount of the bid. This original bid security / bid bond must be submitted to the City Clerk's Office *at least one hour prior* to the bid submission deadline. Any and all **late** submittals of the bid security / bid bond **shall** be rejected, and it is the bidder's responsibility, *not* the delivery service, to ensure said bid security / bid bond is delivered timely to the City Clerk's office. The Bidder's Bond shall be signed by both, the Bidder and the Surety; and both signatures shall be notarized. The bid security shall be given as a guarantee that the Bidder, if awarded the work, shall execute the contract in conformity with the Contract Documents and shall provide the surety bond or bonds as specified therein within fourteen (14) calendar days after a written Notice of Intent to Award Contract is deposited in the mail. In the case of refusal or failure to enter into said contract, the check or bond, as the case may be, shall be forfeited to the City.
4. NONCOLLUSION AFFIDAVIT: Each bid shall be accompanied by a notarized Noncollusion Affidavit on a form which is included in the Contract Documents.
5. SIGNATURE: Via the *PlanetBids* platform, the bid must be *electronically* or *digitally* signed in the name of the Bidder and must be person or persons duly authorized to sign the bid on behalf of the Bidder.
6. CORRECTIONS: Any corrections made to the submitted bid must be made electronically via *PlanetBids*.
7. DELIVERY OF PROPOSAL: Proposals shall be submitted electronically via PlanetBids: <https://www.planetbids.com/portal/portal.cfm?CompanyID=45476>. No other form of submittal shall be accepted by the City.

8. **BID DEPOSIT RETURN:** Deposits of three of more low bidders, the number being at the discretion of the City, will be held for sixty (60) calendar days or until posting by the successful bidder of the Bonds and Certificates of Insurance required and return of executed copies of the Agreement, whichever first occurs, at which time the deposits will be returned.
9. **TAXES:** No mention shall be made in the proposal of Sales Tax, Use Tax or any other tax, as all amounts bid will be deemed and held to include any such taxes which may be applicable.
10. **WITHDRAWAL OF BIDS:** Any bidder may withdraw his bid either personally, by written request, or by telegraphic request confirmed in the manner specified above at any time prior to the scheduled closing time for receipt of bids.
11. **AGREEMENT AND BONDS:** The Agreement form, which the successful bidder, as Contractor, will be required to execute, and the forms and amounts of surety bonds and Certificate of Insurance which he will be required to furnish prior to the execution of the Agreement, are included in the Contract Documents and should be carefully examined by the Bidder. The successful Bidder will be required to submit **THREE (3)** executed copies of the Agreement, the Performance Bond, the Payment Bond and the Certificate of Insurance. Payment and performance bonds shall be issued by a surety who is listed in the latest revision of U.S. Department of Treasury Circular 570 and Code of Civil Procedure Section 995.120. The Performance Bond and the Payment Bond shall be signed by both, the Bidder and the Surety; and both signatures shall be notarized.
12. **FORFEITURE FOR FAILURE TO POST SECURITY AND EXECUTE AGREEMENT:** In the event the Bidder to whom the Notice of Intent to Award Contract is given fails or refuses to post the required bonds and Certificate of Insurance and return executed copies of the Agreement within fourteen (14) calendar days after notification, the City may declare the Bidder's bid deposit or bond forfeited as damages caused by the failure of the bidder to post such security and execute such copies of the Agreement, and may give Notice of Intent to Award Contract to the next lowest responsive and responsible bidder, or may call for new bids.
13. **BIDDERS INTERESTED IN MORE THAN ONE BID:** No person, firm or corporation shall be allowed to make, or file or be interested in more than one bid for the same work unless alternate bids are specifically called for.
14. **EXAMINATION OF SITE AND CONTRACT DOCUMENTS:** Each bidder shall visit the site of the proposed work and fully acquaint himself with the conditions relating to the construction and labor so that he may fully understand the facilities, difficulties, and restrictions attending the execution of the work under the contract. Bidders shall thoroughly examine and be familiar with the drawings and specifications. The failure or omission of any bidder to receive or examine any contract document, form, instrument, addendum, or other document or to visit the site and acquaint himself with conditions there existing shall in no way relieve any bidder from any obligation with respect to his bid or to the contract. The submission of a bid shall be taken as prima facie evidence of compliance with this section.
15. **INTERPRETATION OF PLANS AND DOCUMENTS:** If any Bidder contemplating submitting a bid for the proposed contract is in doubt as to the true meaning of any part of the drawings, specifications, or other Contract Documents, or finds discrepancies in, or

omissions from the drawings and specifications, it may submit to the Engineer a written request for an interpretation or correction thereof. The Bidder submitting the Request for Interpretation (RFI) shall be responsible for its prompt delivery and on the form included within this IFB (Page B-5). Any interpretation or correction of the Contract Documents will be made only by addendum duly issued and a copy of such addendum will be mailed or delivered to each person receiving a set of the Contract Documents. No person is authorized to make any oral interpretation of any provision in the Contract Documents to any Bidder, and no Bidder is authorized to rely on any such unauthorized oral interpretation.

16. **ADDENDA:** The effect of all addenda to the Contract Documents shall be considered in the bid package and said addenda shall be made part of the Contract Documents and shall be returned with the bid package. Failure to submit any such addenda with the bid package may render the bid irregular and result in its rejection by the City.
17. **QUESTIONS TO THE ENGINEER:** *Pre-bid questions and requests for interpretation (RFIs) of the bid documents (i.e. Plans, Specifications, Contract Documents, Bid Forms, etc.) shall be submitted no later than 5:00 PM Monday, August 22, 2022. Any questions or RFI requests submitted after the advertised date may not receive a response. Substitution proposals will only be considered during the bidding phase.*
18. **EQUIVALENT MATERIALS:** *Requests for the use of equivalents to those specified, must be submitted to the City during the bidding phase. All substitution proposal requests shall be submitted to the City for review no later than 5:00 pm Monday, August 22, 2022. No substitution proposals will be accepted after the advertised date, and substitutions will not be considered after award. It is the sole responsibility of the successful bidder to prove to the City that a proposed substitute is truly an equivalent to what has been specified.*
19. **EVIDENCE OF RESPONSIBILITY:** Upon the request of the City, a bidder whose bid is under consideration for the award of the contract shall submit promptly to the City satisfactory evidence showing the Bidder's financial resources, its construction experience, and its organization and plant facilities available for the performance of the contract.
20. **LEGAL RESPONSIBILITIES:** All proposals must be submitted, filed, made and executed in accordance with State and Federal laws relating to bids for contracts of this nature whether the same or expressly referred to herein or not. Any Bidder submitting a proposal shall by such action thereby agree to each and all of the terms, conditions, provisions and requirements set forth, contemplated and referred to in the Plans, Specifications and other Contract Documents, and to full compliance therewith. Additionally, any Bidder submitting a proposal shall, by such action thereby, agree to pay at least the minimum prevailing per diem wages as provided in Section 1773, et. seq. of the Labor Code for each craft, classification or type of workman required as set forth by the Director of Industrial Relations of the State of California.
21. **ANTI-DISCRIMINATION:** It is the policy of the City that in connection with all work performed under contracts, there be no discrimination against any prospective or active employee engaged in the work because of race, color, ancestry, national origin, religious creed, sex, age, or marital status. The Contractor agrees to comply with applicable Federal and California laws including, but not limited to, the California Fair Employment Practice Act, beginning with Government Code Section 12900, and Labor Code Section 1735. In addition, the Contractor agrees to require like compliance by any subcontractors employed on the work by him/her.

22. **DRUG-FREE WORKPLACE POLICY:** Contractor, upon notification of contract award, shall establish a Drug-Free Awareness Program to inform employees of the dangers of drug abuse in the workplace, the penalties that may be imposed upon employees for drug abuse violations occurring in the workplace, and the employee assistance programs available to employees. Each employee engaged in the performance of a City contract must be notified of this Drug-Free Awareness Program, and must abide by its terms. Contractor shall conform to all the requirements of City's Policy No. 100-5. Failure to establish a program, notify employees, or inform the City of a drug-related workplace conviction will constitute a material breach of contract and cause for immediate termination of the contract by the City.
23. **BID PROTEST PROCEDURES:** Any bid protest must be submitted in writing before 5:00 PM of the 5th business day following bid openings. The initial protest document shall contain a complete statement of the basis for the protest. The protest shall refer to the specific portion of the document which forms the basis for the protest. The protest shall include the name, address and telephone number of the person representing the protesting party. The party filing the protest shall concurrently transmit a copy of the initial protest document and any attached documentation to all other parties with a direct financial interest which may be adversely affected by the outcome of the protest. Such parties shall include all other Bidders or proposers who appear to have a reasonable prospect of receiving an award depending upon the outcome of the protest. Upon receipt of a bid protest, the matter shall be reviewed by the Public Services Director, whose decision shall be final. This procedure supersedes the procedure of appeal outlined in City of Costa Mesa Municipal Code Section 2-303.
24. **ASSEMBLY BILL 626:** Assembly Bill 626 (AB 626), adds section 9204 to the Public Contract Code creating a claims resolution process applicable to any claim (as defined) by a contractor against a public entity filed in connection with a public works project. Section 9204 applies to public works contracts entered into on and after January 1, 2017. The legislation was supposed to sunset (end) on January 1, 2020, unless extended by subsequent legislation. The summary of Section 9204 is specified as follows:

In the event of any dispute or controversy with the City over any matter whatsoever, the Contractor shall not cause any delay or cessation in or of Work, but shall proceed with the performance of the Work in dispute. The Contractor shall retain any and all rights provided that pertain to the resolution of disputes and protests between the parties. The Disputed Work will be categorized as an "unresolved dispute" and payment, if any, shall be as later determined by agreement or a court of law. The Contractor shall keep accurate, detailed records of all Disputed Work, claims and other disputed matters.

All claims arising out of or related to the Contract Documents or this Project, and the consideration and payment of such claims, are subject to the Government Claims Act (Government Code Section 810 et seq.) with regard to filing claims. All such claims are also subject to the dispute procedures set forth in Public Contract Code Section 9204 and Public Contract Code Section 20104, et seq. (Article 1.5), to the extent each is applicable. This Contract hereby incorporates those provisions as through fully set forth herein. Thus, the Contractor or any Subcontractor must file a claim in accordance with the Government Claims Act as a prerequisite to filing a construction claim in compliance with Section 9204 and Section 20104 et seq. (if applicable), and must then adhere to Section 20104, et seq. and Section 9204, as applicable, pursuant to the definition of "claim" as individually defined therein.

REQUEST FOR INTERPRETATION OF CONTRACT DOCUMENTS

Date: _____

Time: _____

Company: _____

Contact Person: _____

Address: _____

Telephone: _____

FAX: _____

Plan Sheet: _____

Specification Section: _____

INTERPRETATION REQUESTED:

REPLY:

TO A/E: _____

SECTION C
[PROPOSAL FORM INTENTIONALLY OMITTED]

SECTION D

PART 1

GENERAL PROVISIONS

SECTION 1 – GENERAL

1-1 GENERAL

[Add the following:].

Except as hereinafter provided, the provisions of the latest edition of the Standard Specifications for Public Works Construction ("Green Book"), and all amendments thereto, adopted by the Joint Cooperative Committee of Southern California Chapter, American Public Works Association, Southern California District and Associated Contractors of California; hereinafter referred to as Standard Specifications, are adopted as the "Standard Specifications of the City of Costa Mesa" and shall be considered as a part of these specifications. Copies of the Standard Specifications are available from the publisher:

BNi Building News
1612 S. Clementine Street
Anaheim, California 92802
(714) 517-0971

Where specified in these specifications, the latest edition of the California Building Code, based on the latest edition of the International Building Code, the latest edition of the "Standard Specifications and Standard Plans of the State of California, Department of Transportation, Division of Highways," "Standard Plans of the Orange County Environmental Management Agency," and "Los Angeles County Flood Control District, Design Manual, Standard Drawings" shall apply or unless otherwise noted in these specifications or at the direction of the ENGINEER.

Where referenced in these Specifications, the latest edition of the "City of Costa Mesa Standard Drawings" and the "Work Area Traffic Control Handbook (WATCH)" published by Building News, Inc., shall also apply.

The section numbers of these General Provisions coincide with those of the said Standard Specifications. Only those sections requiring amendment, elaboration, or specifying options, are called out.

The following modifications are made to the "Standard Specifications." If there is a conflict between the "Standard Specifications" and these modifications, these modifications shall have first precedence.

1-6 BIDDING AND SUBMISSION OF THE BID

1-6.1 General

[Add the following:].

Proposal shall be made and submitted on proposal forms **P-1** through **P-11** in accordance with the Notice Inviting Bids. In addition to the required signatures in the spaces provided in the proposal forms, each BIDDER shall initial each sheet of the proposal forms at the bottom right hand corner.

No person, firm, partnership, corporation, or combination thereof shall be allowed to make or file or be interested in more than one bid for the same work, unless alternate bids are called for. A person, firm, partnership, corporation, or combination thereof who has submitted a sub-proposal to a BIDDER or who has quoted prices on materials to a BIDDER is not thereby disqualified from submitting a sub-proposal to or quoting prices to the other bidders. If, on the opening of bids, more than one bid appears in which the same person, firm, partnership, corporation or combination thereof is interested as a principal, all such bids shall be rejected.

Proposals with interlineations, alterations, or erasures shall be initialed by the BIDDER'S authorized agent. Alternative proposals, special conditions, or other limitations or provisions affecting the bid, except as such called for in the contract documents, will render the bid informal and may cause its rejection.

All proposals must give the prices bid for the various items of work and must be signed by the BIDDER, who shall give his address. Each bid shall have thereon the affidavit of the BIDDER that such bid is genuine and not sham nor collusive, nor made in the interest nor behalf of any other person not therein named and that the BIDDER has not directly nor indirectly induced or solicited any other BIDDER to put in a sham bid, nor induced nor solicited any person, firm, partnership, corporation, or combination thereof to refrain from bidding, and that the BIDDER has not in any manner sought by collusion to secure himself an advantage over any other BIDDER.

A contractor or subcontractor shall not be qualified to bid on, be listed in a bid proposal, subject to the requirements of Section 4104 of the Public Contract Code, or engage in the performance of any contract for public work, as defined in this chapter, unless currently registered and qualified to perform public work pursuant to Section 1725.5 of the Labor Code. It is not a violation of this section for an unregistered contractor to submit a bid that is authorized by Section 7029.1 of the Business and Professions Code or by Section 10164 or 20103.5 of the Public Contract Code, provided the contractor is registered to perform public work pursuant to Section 1725.5 at the time the contract is awarded.

1-6.1.1 Request for Interpretation

If any person contemplating submitting a bid is in doubt as to the meaning of any part of the Plans, Specification, or other proposed Contract Documents, or finds discrepancies in, or omissions from the drawings or specifications, (It, he, she) may make a request to the ENGINEER, in writing, for an interpretation or correction thereof pursuant to the provisions in the Information for Bidders section of these specifications. The person

submitting such a request shall be responsible for its prompt delivery. All such interpretations of the Contract Documents will be made only by addenda duly issued, and a copy of each such addendum will be mailed or delivered to each person receiving a set of Contract Documents at (its, his, her) last address of record. The CITY will not be responsible for any other explanations or interpretations of the Contract Documents.

1-6.1.2 Soil Conditions

The BIDDER shall inspect the soil conditions before submitting a bid. By submitting a bid, the BIDDER acknowledges that he is satisfied with the quality of the work area including but not restricted to the conditions affecting, handling and storage of materials, disposal of excess materials, and the soil conditions.

1-6.1.3 Return of Bid Security

Any BIDDER may withdraw its bid, either personally, or by telegraphic or written request, at any time prior to the scheduled closing time for the receipt of bids. It is the sole responsibility of the BIDDER to see that any such telegraphic or written request is delivered to the City Clerk prior to said closing time. Bid security of such BIDDERS will be returned promptly to the BIDDER.

The bid security of the BIDDER whose bid is accepted will be held by the CITY until the contract has been executed and the accompanying insurance certificates, performance bond and labor and materials bond are approved and filed, whereupon the bid security will then be returned to the BIDDER.

The bid security of the second and third lowest BIDDERS will be retained until the contract is awarded to and executed by the BIDDER whose bid is accepted, or until 45 days after the opening of bids, whichever period is shorter. The bid security of all BIDDERS other than the three lowest will be returned promptly after the opening of bids.

If a BIDDER fails or refuses promptly to execute the agreement to do the work or fails or refuses to comply with insurance and bonding requirements, the bid security shall be forfeited to the CITY and shall be collected and paid into the General Fund of the CITY.

1-6.2 Subcontractor Listing

[Add the following:].

The ENGINEER, as duly authorized officer, may consent to subcontractor substitution requested by the Contractor subject to the limitations and notices prescribed in Section 4107 of the Public Contract Code.

1-7 AWARD AND EXECUTION OF THE CONTRACT

1-7.1 General

[Add the following:].

The award of contract, if awarded, will be to the lowest responsive and responsible bidder whose proposal complies with all requirements of the Notice Inviting Bids and Section 1-6 of these specifications. The BIDDER, upon notification as the "apparent low bidder," shall comply with the CITY'S insurance and bonding requirements by submitting the required insurance certificates and bonds within **fourteen (14) days after the mailing of a Notice of Award to the BIDDER that the contract is ready for execution**. The contract will be awarded within thirty (30) days of receipt of properly approved insurance certificates and bonds pursuant to CITY requirements spelled out in these specifications. BIDDER must take particular note of "insurance requirements" contained in these specifications and sample agreement included within the contract documents, and should provide that information to his insurance broker in order that a properly executed certificate is submitted. The CITY, however, reserves the right to reject any or all bids and to waive any informality in the bids received.

1-7.1.1 Execution of Agreement

The Agreement shall be signed by the successful BIDDER and returned to the CITY no later than **fourteen (14) days from Notice of Award** of the Contract by the CITY. Failure to comply with insurance and bonding requirements as specified in the Agreement and in Section 1-7.1 of these General Provisions shall be considered grounds for the revocation and rejection of the bid and forfeiture of bid security. No proposal shall be considered binding upon the CITY until the execution of the agreement by the CITY. In case of conflict, the agreement shall have precedence over all other written specifications.

1-7.2 Contract Bonds

[Add the following:].

The "Faithful Performance Bond" and the "Labor and Material Bond" as specified in this section shall be for one hundred percent (100%) of the Contract price. The Labor and Material Bond shall be maintained by the Contractor in full force and effect for at least seven (7) months following the filing of the Notice of Completion. The Faithful Performance Bond shall also be kept by the Contractor in full force and effect for at least one (1) year following the filing of the Notice of Completion.

CONTRACTOR shall provide the following:

- A certified copy of the certificate of authority of the surety issued by the Insurance Commissioner.
- A certificate from the clerk of the county in which the court or officer is located that the certificate of authority of the surety has not been surrendered, revoked, canceled, annulled, or suspended or, in the event that it has, that renewed authority has been granted.
- Copies of the surety's most recent annual statement and quarterly statement filed with the Department of Insurance pursuant to Article 10 (commencing with Section 900) of Chapter 1 of Part 2 of Division 1 of the Insurance Code.

SECTION 2 – SCOPE OF THE WORK

2-1 WORK TO BE DONE

[Replace in its entirety with the following:].

The CONTRACTOR shall perform all work necessary to complete the Contract Agreement in accordance with the Contract Documents.

The CONTRACTOR shall provide and furnish all labor, operations, materials, tools, equipment, supplies, manufactured articles, and incidentals necessary to perform and complete the Work as shown on the Plans and these Contract Documents, to the satisfaction of the ENGINEER.

Reference the Special Provisions for specific project details.

2-2 PERMITS

[Add the following:].

All permits and licenses shall be obtained in sufficient time to prevent delays to the work. Permit fees for all City-issued permits shall be waived. Fees for any other permits must be paid by the Contractor and be included in the price bid for this work.

In the event that the CITY has obtained permits, licenses or other authorizations applicable to the work, the Contractor shall comply with the provisions of said permits, licenses and other authorizations.

2-5 THE CONTRACTOR'S EQUIPMENT AND FACILITIES

2-5.1 General

[Add the following:].

The Contractor shall only use the proper construction equipment to protect the City streets from breaking up and deterioration. Haul trucks shall be limited to a gross vehicle weight of 10 tons or less.

2-5.2 Temporary Utility Services

[Add the following:].

The Contractor shall provide for his employees an adequate supply of clean, potable drinking water, which shall be dispensed through approved sanitary facilities.

If water is needed during construction, Contractor shall contact Mesa Consolidated Water District to obtain necessary permits, instructions, and meters prior to commencing work. The Contractor is required to make any and all necessary installations and connections. All water shall be metered. The Contractor shall pay for all deposits and fees involved.

2-5.4 Haul Routes

[Add the following:].

In order to protect the City streets from deterioration due to hauling of materials, the Contractor shall submit to the ENGINEER (at the pre-construction meeting) for approval, a proposed route for the hauling of materials for disposal. Upon approval, the Contractor shall strictly adhere to that route only, unless written permission from the ENGINEER is obtained to change the route.

Where haul routes have not been established at a pre-construction meeting the Contractor shall submit to the ENGINEER for approval, a proposed haul route at least 5 working days prior to performing any work that requires hauling.

Waste Hauler Requirements

The California Green Building Standards Code, 2016 Edition, California Code of Regulations, Title 24, Part 11, impacting waste diversion as documented in the City of Costa Mesa's Municipal Code Chapter 4 of Title 8, requires that all construction and demolition related projects divert 65% of project waste generated from the landfill. Consequently, permitted building projects relating to construction and demolition, newly constructed buildings, additions, alterations, interior and exterior demolitions, etc., are required to divert a minimum of 65% of nonhazardous construction and demolition waste from the landfill by recycling, reuse, or salvage. Generally, these materials include brick, drywall, other masonry, cardboard, green waste, paper, carpet, lumber, plastic, concrete, and/or metals. Asphalt, concrete, excavated soil and land-clearing debris should be 100% diverted from disposal. The County provides a suggested list of locations that are meeting and/or exceeding the 65% diversion requirement and may be used for recycling construction and demolition material.

The City of Costa Mesa requires that all hauling activity in Costa Mesa comply with one of the waste hauling options for your construction and demolition related project:

- Use Franchise Waste Hauler
- Self-Haul Permit - <https://www.costamesaca.gov/city-hall/city-departments/public-services/waste-collection-and-recycling>

A Construction and Demolition Reporting Form as provided in the Miscellaneous Document Section of these Specifications must be completed and submitted by the Contractor to the CITY prior to the release of retention monies.

2-7 CHANGES INITIATED BY THE AGENCY**2-7.1 General**

[Add the following:].

ENGINEER shall be the duly authorized officer of the CITY who may grant the changes prescribed in this section.

2-8 EXTRA WORK

[Add the following:].

The extra work as defined in this section of the Standard Specifications and any work done by the Contractor beyond the lines and grades shown on the plans shall only be performed when ordered in writing by the ENGINEER. In absence of such written order, any such work by the Contractor shall be considered unauthorized and will not be paid. Work so done may be ordered to be removed at the Contractor's expense.

2-9 CHANGED CONDITIONS

[Add the following:].

The Contractor shall promptly act to supply all information to the ENGINEER for proper evaluation. Failure to do so shall constitute a waiver of any payment for delays suffered by the Contractor.

SECTION 3 – CONTROL OF THE WORK

3-1 ASSIGNMENT

[Replace the 1st sentence with the following:].

No contract or portion thereof may be assigned without written consent of the BOARD.

3-4 AUTHORITY OF THE BOARD AND THE ENGINEER

[Add the following:].

When any of the various units or operations of the work have been suspended, the Contractor shall give at least 24 hours advance notice of the time when he or his subcontractor will start or resume any of such units or operations. That notice is to be given during working hours, exclusive of Saturdays, Sundays or holidays, for the purpose of permitting the ENGINEER to make necessary assignments to his representative on the work.

Any work performed in conflict with said notice, without the presence or approval of the ENGINEER, or work covered up without notice, approval or consent may be rejected or ordered to be uncovered for examination at Contractor's expense and shall be removed at Contractor's expense, if so ordered by the ENGINEER or his representative on the work. Any unauthorized or defective work, defective material or workmanship or any unfaithful or imperfect work that may be discovered before the final payment and final acceptance of work shall be corrected immediately by the Contractor without extra charge even though it may have been overlooked in previous inspections and estimates or may have been caused due to failure to inspect the work.

All authorized alterations affecting the requirements and information given on the approved plans shall be in writing. No changes shall be made on any plan or drawing by the Contractor after the same has been approved by the ENGINEER, except by direction of the ENGINEER in writing. Deviations from the approved plans, as may be required by critical conditions of construction, must be authorized in writing by the ENGINEER.

All instructions, rulings and decisions of the ENGINEER shall be in writing and are binding on all parties unless a formal protest is made as provided in the following paragraph:

If the Contractor considers any work demanded of him to be outside the requirements of the contract, or if he considers any instruction, ruling or decision of the ENGINEER or ENGINEER'S representative to be unfair, the Contractor shall, within ten (10) days after any such demand is made, or instruction, ruling or decision is given, file a written protest with the ENGINEER, stating clearly and in detail his objections and reasons therefor. Except for such protests and objections as are made of record, in the manner and within the time above stated, the Contractor shall be deemed to have waived and does hereby waive all claims for extra work, damages and extensions of time on account of demands, instructions, rulings and decisions of the ENGINEER.

Upon receipt of any such protest from the Contractor, the ENGINEER shall review the demand, instruction, ruling or decision objected to and shall promptly advise the

Contractor, in writing, of his final decision, which shall be binding on all parties, unless within the ten (10) days thereafter the Contractor shall file with the BOARD a formal protest against said decision of the ENGINEER. The BOARD shall consider and render a final decision on any such protest within thirty (30) days of receipt of same. If the BOARD fails to consider and render a final decision on any such protest within thirty (30) days of receipt of the same, the protest shall be deemed denied.

3-5 INSPECTION

[Add the following:].

If the Contractor requests and receives approval from the ENGINEER to receive inspection services from the CITY outside of a normal eight (8) hour day/forty (40) hour work week or on Saturday, Sunday, or CITY holidays, the Contractor shall arrange with the CITY and ENGINEER for the special inspection services and Contractor shall pay for such special inspection services at a fee established by the ENGINEER to defray the cost for such service.

All work, which has been inspected and deemed defective in its construction or does not meet all of the requirements of the plans and/or specifications by the ENGINEER shall be remedied, or removed and replaced by the Contractor in an acceptable manner, and no compensation will be allowed for such correction.

Any work done beyond the limits of the lines and grades shown on the plans or established by the ENGINEER or extra work done without written authority will be considered as unauthorized and not be paid.

Upon failure on the part of the Contractor to comply with any order of the ENGINEER made under the provisions of this article, the ENGINEER shall have authority to cause defective work to be remedied, or removed and replaced, and unauthorized work to be removed, and to deduct the costs and thereof from any monies due or to come due the Contractor.

Payment will not be made for materials wasted or disposed of in a manner not called for under the Contract. This includes rejected material not unloaded from vehicles, material rejected after is has been placed and material placed outside the limits of the project. No compensation will be allowed for disposing of rejected or excess material.

3-6 THE CONTRACTOR'S REPRESENTATIVE

[Add the following:].

Contractor shall file with the ENGINEER the addresses and telephone numbers where its designated representative may be reached during hours when the work is not in progress.

Instructions and information given by the ENGINEER to the Contractor's authorized representative or at the address or telephone numbers filed in accordance with this section shall be considered as having been given to the Contractor.

The Contractor shall have on the work site at all times a competent English-speaking superintendent, as his agent, capable of reading and thoroughly understanding the

plans and specifications and other related documents.

3-7 CONTRACT DOCUMENTS

3-7.1 General

[Add the following:].

Contractor will obtain from the ENGINEER, free of charge, copies of plans, general provisions, special provisions and additions to the Standard Specifications that are reasonably necessary for the execution of work.

Contractor shall, at its own expense, obtain copies of the Standard Specifications and Standard Plans and Specifications of CALTRANS, for his general use.

If after the Contract is awarded it appears that the work to be done, or any matter relative thereto, is not sufficiently detailed or explained in the specifications and plans, the Contractor shall apply to the ENGINEER for such further explanations as may be necessary and shall conform to such explanation or interpretation as part of the Contract.

All scaled dimensions are approximate. Before proceeding with the work, the Contractor shall carefully check and verify all dimensions and quantities and shall immediately inform the ENGINEER or his representative of any discrepancies.

3-10 SURVEYING

[Replace with the following:].

3-10.1 General

The Contractor will perform and be responsible for the accuracy of setting all required survey stakes adequate for the construction of the project.

3-10.3 Line and Grade

Unless otherwise provided in the Special Provisions, lines and grades for construction shall be the responsibility of the Contractor, with the following provisions:

All work under this Contract shall be built in accordance with the lines and grades shown on the plans. Field survey for establishing the lines and grades and for the control of construction shall be the responsibility of the Contractor. All such surveys, including construction staking, shall be under the supervision of a California-licensed land surveyor or by a California-licensed civil engineer allowed by law. Staking shall be performed on all items ordinarily requiring grade and alignment, at intervals normally accepted by the agencies and the trade involved.

The Contractor shall provide a copy of the office calculations and grade sheets to the City Inspector. The Contractor shall be responsible for any error in the finished work and shall notify the ENGINEER within one (1) working day of any discrepancies or design errors discovered during staking.

Unless a separate bid item is provided, the payment for surveying, construction staking, professional services, office calculations, furnishing all labor, materials, equipment, tools and incidentals, and for doing all work involved shall be considered as included in the various items of work, and no additional compensation will be allowed.

3-12 WORK SITE MAINTENANCE

3-12.1 General

[Replace 2nd paragraph with the following:].

Unless the construction dictates otherwise, and unless otherwise approved by the ENGINEER, Contractor shall furnish and operate a self-loading motor sweeper with a functional water spray nozzle system at least once each working day to keep paved areas in the Work zone and along all haul routes acceptably clean whenever construction, including restoration, is incomplete.

3-12.2 Air Pollution Control

[Add the following:].

Failure of the Contractor to comply with the ENGINEER'S dust control orders may result in an order to suspend work until the condition is corrected and, after giving notice to the Contractor, the ENGINEER may order the condition corrected by others. All costs thus incurred shall be deducted from the amount to be paid to Contractor. No additional compensation will be allowed as a result of such suspension.

No separate payment will be made for any work performed nor material used to control dust resulting from Contractor's performance of the work or from public traffic, either inside or outside the right-of-way. Full compensation for such dust control will be considered to be included in the prices paid for the various items of Work involved.

3-12.4.1 General

[Add the following:].

All surplus materials shall be removed from the site of the Work within five (5) days after completion of the Work causing the surplus materials.

3-12.6 Water Pollution Control

3-12.6.1 General

[Add the following:].

Discharge of storm water from construction sites that disturb land equal to or greater than one (1) acre must be in compliance with the state General Construction Activity Permit (Construction Permit). The latest permit provisions of the Construction Permit shall apply. The Contractor is required to contact the Santa Ana Regional Water Quality

Control Board (Regional Board) for all information contained in the Construction Permit. In the event project construction occurs during the transition of revised Construction Permits, the Contractor shall incorporate the necessary modifications specified by the revised Construction Permit within the time period specified in the new Construction Permit.

Project Soil Disturbance is:

Less than 1 acre .: No General Construction Permit required

Construction activity subject to the Construction Permit includes clearing, grading, disturbance to the ground such as stockpiling, work area, or excavation that results in soil disturbances of at least one acre of total land area. Construction activity that results in soil disturbances of less than one acre is subject to the Construction Permit if the construction activity is a part of a larger common plan of development that encompasses one or more acres of soil disturbance or if it is determined that discharges from the project pose a significant threat to water quality.

The CONTRACTOR shall have an account with the State for SMARTS (Storm Water Multiple Application and Report Tracking System). The CONTRACTOR shall contact the CITY with their user ID so that the CITY will grant the CONTRACTOR access as a Data Submitter.

The CONTRACTOR shall complete the NOI within SMARTS <https://smarts.waterboards.ca.gov/smarts/faces/SwSmartsLogin.jsp>. The CONTRACTOR will notify the CITY when the NOI is ready for the CITY to submit to the State. The CONTRACTOR shall pay all fees associated with the NOI process. The CONTRACTOR shall also complete all required reports within SMARTS as required by the General Permit and the Project's Storm Water Pollution Prevention Plan (SWPPP).

The CONTRACTOR shall complete the Annual Report and NOT within SMARTS. Once the CITY has been notified, the CITY will review and submit to the State for processing.

A copy of the latest permit is available at:

http://www.waterboards.ca.gov/water_issues/programs/stormwater/constpermits.shtml

The CONTRACTOR is hereby directed to read the Construction Permit thoroughly and comply with the requirements as specified therein.

3-12.6.2 Best Management Practices (BMPs)

[Add the following:].

The Contractor shall install and maintain the appropriate Best Management Practices (BMPs) to protect water quality within the project limits through the duration of the Project.

The Contractor shall be responsible for any damage to any portion of the Work occasioned by failure to provide proper drainage control prior to the completion and acceptance of the Work.

Payment for furnishing, installing and maintaining BMPs inclusive of sweeping the Project site as required or directed by the ENGINEER shall be included in the other various bid items associated with the work and no additional payment will be allowed thereof.

3-12.6.3 Storm Water Pollution Prevention Plan (SWPPP)

[Add the following:].

If a General Construction Permit is required pursuant to Section 3-12.6.1 of these General Provisions, the following Storm Water Pollution Prevention Plan (SWPPP) requirements shall be adhered to:

The Contractor is responsible for the preparation and implementation of a SWPPP as required by the Construction Permit. The Contractor is responsible for completing all parts of the SWPPP including, REAPs, monitoring, sampling, rain gauge records, weather reports, submitting pictures of every third storm, non-authorized discharge reports, Ad-Hoc reports, Annual Reports, post construction BMPs and other requirements of the SWPPP.

The completed SWPPP must be signed by a QSD (Qualified SWPPP Developer). The completed SWPPP must be submitted to the resident engineer for City review and acceptance, prior to uploading to SMARTS. The Contractor will be responsible for uploading an electronic format of the SWPPP into SMARTS. The SWPPP must be signed by the City before construction begins. A copy of the SWPPP must be available at the site at all times and must be implemented and revised in accordance with the Construction Permit throughout the duration of the project.

Contractor must have QSP (Qualified SWPPP Practitioner). Contractor shall perform site inspections before and after the storm event, and once each 24-hour period during extended storm event, to identify BMP effectiveness and implement repairs or BMP modifications as soon as possible. Sampling of potential pollutant discharges shall be conducted by trained personnel and required laboratory test conducted by laboratory accredited by the California Department of Health Services Environmental Laboratory Accreditation Program.

Contractor shall be responsible for any penalties assessed against the City if the penalty assessed is due to Contractor's violation of the Construction Permit requirement, or Contractor's failure to fully implement and monitor SWPPP as required.

Erosion and Sediment Control Plans

Erosion and Sediment Control Plans shall be prepared by the Contractor as part of the SWPPP that identify adequate controls to prevent erosion and discharge of sediment off-site. Payment for the Erosion and Sediment Control Plans shall be included as part of the SWPPP.

3-12.6.4 Dewatering

[Add the following:].

Unless otherwise directed in these Special Provisions, the Contractor shall provide and maintain ample means and devices with which to promptly remove and properly dispose of water entering the excavations or other parts of the work at all times during construction. Dewatering shall be accomplished by methods which will ensure a dry excavation and preservation of the final lines and grades of the bottoms of excavations. The methods may include sump pumps, deep wells, well points, suitable rock or gravel placed below the required bedding for draining and pumping purposes, temporary pipelines, and other means.

Standby pumping equipment shall be on the job site. A minimum of one standby unit shall be available for immediate installation should any well unit fail. The design and installation of well points or deep wells shall be suitable for the accomplishment of the work. Drawings or details indicating the proposed dewatering system shall be submitted to the CITY for review.

The Contractor shall dispose of the water from the work in a suitable manner without damage to adjacent property.

Conveyance of the water shall be such as to not interfere with traffic flow or treatment facilities operations. No water shall be drained into work built or under construction without prior consent of the ENGINEER.

Water shall be disposed of in such a manner as not to be a menace to the public health and such disposal shall be performed in accordance with Environmental Protection Agency and State Water Quality Control Board standards (NPDES permit). Any testing and reports required under NPDES permit shall be performed by the Contractor and submitted to the appropriate agency for approval at no additional cost to the CITY.

3-13 COMPLETION, ACCEPTANCE, AND WARRANTY

3-13.3 Warranty

[Replace 2nd sentence of 1st paragraph with the following:].

The warranty period shall start on the date the Work is accepted by the Board.

SECTION 4 – CONTROL OF MATERIALS

4-4 TESTING

[Add the following:].

All tests of materials furnished by the Contractor shall be made in accordance with commonly recognized standards of national organizations and such special methods and tests as are prescribed in these specifications. No materials shall be used until they have been approved by the ENGINEER.

The Contractor shall at his expense furnish the CITY, in triplicate, certified copies of all required factory and mill test reports. Any materials shipped by the Contractor from a factory or mill prior to having satisfactorily passed such testing and inspection by a representative of the CITY shall not be incorporated in the work, unless the ENGINEER shall have notified the Contractor, in writing, that such testing and inspection will not be required.

At the option of the ENGINEER, the source of supply of each of the materials shall be approved by the ENGINEER before delivery is started and before such material is used in the work.

Unless otherwise provided in the Special Provisions, the CITY will complete and pay for the initial soils, compaction, and material tests. Any subsequent soil, compaction, and material tests deemed necessary due to the failure of initial tests will be at the Contractor's expense and deducted from the payment due.

SECTION 5 – LEGAL RELATIONS AND RESPOSIBILITIES

5-1 LAWS AND REGULATIONS

[Add the following:].

The Contractor shall protect and indemnify the CITY, the BOARD, the ENGINEER, and all of its or their officers, agents and servants against any claim or liability arising from or based on the violation of any existing or future State, Federal and local laws, ordinances, regulations, orders or decrees, whether by himself or his employees. If any discrepancy or inconsistency is discovered in the plans, drawings, specifications or contract for the work in relation to any such law, ordinance, regulation, order or decree, the Contractor shall forthwith report the same to the ENGINEER in writing.

5-2 SPECIAL NOTICES

[Add the following:]

In addition to the special notices requirement to be served by Personnel Delivery or Certified Mail, special notices may also be served by the utilization of FedEx or UPS express service with a confirmed delivery receipt. Service shall be effective on the date of the receipt of the delivery confirm issued by FedEx or UPS.

5-3 LABOR

5-3.3 Payroll Records

[Add the following:].

In order to verify compliance with the Labor Code, Contractor shall furnish to the ENGINEER, weekly, for the duration of the contract period, copies of his payroll statements showing wages paid to each employee during the preceding week and the employee work classification. Use of Form DH-C-347, Payroll Statement of Compliance, is an acceptable method of fulfilling the above requirement.

5-3.5 Apprentices

[Replace with the following:].

Attention is directed to the provisions of Sections 1777.5 and 1777.6 of the Labor Code concerning the employment of apprentices by the Contractor or any subcontractor under it. The Contractor and any subcontractor under it shall comply with the requirements of those Sections in the employment of apprentices.

Information relative to apprenticeship standards, wage schedules and other requirements may be obtained from the Director of Industrial Relations, Ex-officio the Administrator of Apprenticeship, San Francisco, California, or from the Division of Apprenticeship Standards and its branch offices.

5-4 INSURANCE

[Replace with the following:].

The minimum amounts and types of insurance coverages are as stated in the Agreement (sample copy attached). Prior to bid submittal the BIDDERS shall keep fully

informed of the latest insurance requirements of the City of Costa Mesa and shall comply with all other provisions of Section 5-4 of the Standard Specifications.

Below are approved endorsements which satisfy the basic insurance requirements contained in contracts entered into by City of Costa Mesa. These have been approved by the City Attorney's office. The terms of any specific contract with the City are controlling. Prior to the commencement of any work, the CITY requires that the ENGINEER receive Certificates of Insurance in **DUPLICATE** for liability coverage of at least \$1,000,000 combined single limit, per occurrence and in the aggregate.

Each insurance policy required by the CITY of the Contractor shall contain the following endorsements:

1. Additional Insureds

"The City of Costa Mesa and its elected and appointed boards, officers, agents, and employees are additional insureds with respect to the subject project and agreement."

2. Notice

"Said policy shall not terminate, nor shall it be canceled nor the coverage reduced, until thirty (30) days after written notice is given to City."

3. Other Insurance

"Any other insurance maintained by the City of Costa Mesa shall be excess and not contributing with the insurance provided by this policy."

If any of such policies provide for a deductible or self-insured retention to provide such coverage, the amount of such deductible or self-insured retention shall be approved in advance by City. No policy of insurance issued as to which the City is an additional insured shall contain a provision which requires that no insured except the named insured can satisfy any such deductible or self-insured retention.

5-7 SAFETY

5-7.1 Work Site Safety

5-7.1.1 General

[Add the following:].

Material or other obstructions shall not be placed within fifteen feet (15') of fire hydrants. Fire hydrants shall be made readily accessible to the Fire Department at all times.

5-7.8 Steel Plate Covers

5-7.8.1 General

[Add the following:].

All steel plate covers utilized for the project must be slide resistant. A non-slip coating will be required on the side of the steel plate that that will be utilized for the driving or walking surface.

SECTION 6 – PROSECUTION AND PROGRESS OF THE WORK

6-1 CONSTRUCTION SCHEDULE AND COMMENCEMENT OF THE WORK

6-1.1 Construction Schedule

[Replace the 1st Paragraph with the following:].

The Contractor's proposed Construction Work Schedule shall be submitted to the ENGINEER for approval within ten (10) working days after the date of the BOARD's execution of the Contract Agreement. The Construction Work Schedule shall be supported by written statements from each supplier of materials or equipment indicating that all orders have been placed and acknowledged, and setting forth the dates that each item will be delivered. The Construction Work Schedule shall provide sufficient detail to delineate the main milestones start and end dates for each activity with chronological relationships of all the activities of Work showing the number of working days required to complete the entire project within the Contract Days. The schedule shall also incorporate the requirements of Section 402-5 of the Standard Specifications to complete the Work within the Contract Days. Prior to issuing the Limited Notice-to-Proceed, the ENGINEER will schedule a preconstruction meeting with the Contractor to review the proposed Construction Work Schedule, delivery dates, activity milestone dates, arrange utility coordination, discuss construction methods and staging, and clarify inspection procedures.

The Contractor shall submit progress reports to the ENGINEER by the tenth day of each month. The report shall include an updated Construction Work Schedule. All revisions shall be completed within three days after review by the ENGINEER. The Contractor shall submit requests for changes in the schedule to the CITY for approval at least three (3) working days prior to performing any work. Any deviations from the original approved Construction Work Schedule shall be explained and identified in the updated Construction Work Schedule. Progress payments will be withheld pending receipt of any outstanding reports.

The Contractor shall furnish the ENGINEER with a 3-week look ahead-schedule in a tabular format at every weekly construction meeting. The 3-week look ahead schedule shall utilize the main milestones within the approved Baseline Construction Schedule with updates and include sub-activities.

[Add the following:].

6-1.3 Daily Report Submittal

Contractor shall submit daily reports to the CITY at the end of each working day. All forms shall be provided by the CITY. Any cost for this item shall be included in the various items of work and no other compensation will be allowed.

6-3 TIME OF COMPLETION

6-3.1 General

[Replace the 1st Sentence with the following:].

The Contractor shall begin the Work within **TEN (10) WORKING DAYS** after the date the Contract is executed by CITY unless a later start date is agreed upon by the CITY

and Contractor within written Limited Notice-to-Proceed and Notice-to-Proceed. The **INVESTIGATORY SITE WORK** shall be completed within **NINETY (90) CALENDAR DAYS** from the date set in the Limited Notice-to-Proceed and The **CONSTRUCTION SITE WORK** shall be completed within **TWENTY-FIVE (25) WORKING DAYS** from the date set in the Notice-to-Proceed or the first day of commencement of Work, whichever occurs first.

6-5 USE OF IMPROVEMENT DURING CONSTRUCTION

[Add the following:].

Should it become necessary, due to developed conditions, to occupy any portion of the Work before Contract is fully completed, such occupancy shall not constitute acceptance by the CITY of work by Contractor.

6-7 TERMINATION OF THE CONTRACT FOR DEFAULT

6-7.3 Notice of Termination for Default

[Replace the 1st Paragraph with the following:].

The ENGINEER will make the determination if the Contractor had failed to commence satisfactory corrective action within 5 working days after the receipt of the notice to cure, or to diligently continue satisfactory and timely correction of the default thereafter, and will take action as allowed by the Contract Documents.

6-7.4 Responsibilities of Surety

[Add the following:].

Within 3 working days of receipt of the written notice of termination for default, the Surety shall provide the services needed to maintain the project in accordance with the Contract Documents. The services shall maintain the existing traffic control in place and the maintenance of the project site until the Engineer's review and acceptance of the Surety's plan for course of action.

6-9 LIQUIDATED DAMAGES

[Replace the 1ST Paragraph with the following:].

The CONTRACTOR shall pay to the CITY the sum of **\$525** per calendar day, for each and every calendar day's delay in finishing the Work in excess of the number of Working Days prescribed within these General Provisions and the Agreement, or per the direction of the Engineer. Liquidated damages are calculated per Chapter 12 of the latest edition of the Caltrans Local Assistance Procedures Manual (LAPM).

SECTION 7 – MEASUREMENT AND PAYMENT

7-3 PAYMENT

7-3.1 General

[Replace the 1ST Paragraph with the following:].

Payment for the various items listed on the Bid Proposal, as further specified herein, shall constitute full compensation to the Contractor for furnishing all material, tools, equipment, supplies, and manufactured articles, and for all labor, operations, and incidentals appurtenant to the items of Work and as specified and shown on the drawings, including all costs for compliance with the regulations of public agencies having jurisdiction, including Safety and Health Requirements of the California Division of Industrial Safety and the Occupational Safety and Health Administration (OSHA) of the U.S. Department of Labor. No separate payment will be made for any item that is not specifically set forth in the Bid Proposal. Costs arising from violations of regulations will be paid by the offending party to the extent that there will be no additional cost to the CITY.

When no bid item is provided for work/improvement shown or indicated on the plans and specifications, payment for such work/improvement will be considered to be included in various applicable items of work.

7-3.2 Partial and Final Payment

[Replace the 1st Paragraph in its entirety with the following:].

The closure date for the purpose of making partial progress payments will be the last day of each month. The Contractor may request, in writing, that such monthly closure date be changed. The ENGINEER may approve such request when it is compatible with the CITY's payment procedure.

[Replace the 2nd Paragraph in its entirety with the following:].

Each month, the Contractor shall meet with the Engineer, a minimum of three (3) working days prior to the submittal of the progress payment to the AGENCY, to finalize and receive approval regarding the measurement of the Work performed through the closure date and the estimated value of the progress payment based on the Contract Unit Prices or as provided for in the Standard Specifications. Any progress payment submitted without such approval will be considered incomplete and returned to the Contractor and no payment shall be considered until such approval is obtained.

[Replace the 3rd Paragraph in its entirety with the following:].

The amount retained and deducted by the BOARD shall be 5% of the progress estimates for all progress payments. No reduction in the amount of retention will be allowed. However, after 50% of the work has been completed, if the BOARD finds that satisfactory progress is being made, it may make any of the remaining progress payments in full for actual work completed. The final payment of the retention amount to the Contractor shall be made thirty-five (35) days after the date of the recording of the

Notice of the Completion of the work after it is accepted by the CITY. The 5% withheld from each progress payment shall not include monies withheld for stop notices or other withholding by the CITY. The monies withheld for stop notice and other withholdings shall be in addition to the 5% withheld for retention.

[Add to end of Section the following:].

Contractor shall comply with the requirements of Division 2, Part 1, Chapter 7, Section 7107 of the California Public Contract Code.

The lead time for processing invoices for the monthly progress payments approved by the ENGINEER for inclusion on the warrant list of the CITY is governed by the rules and regulations established by the Finance Department of the CITY. Monthly payments will be processed and paid in accordance with the rules and regulations established or revised by the said Finance Department.

The Contractor shall submit all weight tickets or volumes of all materials used in the construction to the ENGINEER for checking and verification prior to any payment. Failure to do so will postpone the payment to the Contractor, until the matter is resolved satisfactorily.

The weight or volume from submitted tickets must correspond to the work done in the field; if not, the City shall reject the work without compensation to the Contractor, and/or the Contractor shall be directed to replace that work at no additional costs to the City.

After completion of the Contract, the BOARD shall, upon recommendation of the ENGINEER, accept the Work as completed and authorize the Final Payment.

The Final Payment shall be the entire sum found to be due the Contractor after deducting therefrom all previous payments and all amounts to be kept and all amounts to be retained under the provisions of the Contract. All prior partial estimates and payments shall be subject to correction in the final estimate and payment.

No certificate given or payment made under the Contract, except the final certificate or Final Payment, shall be conclusive evidence of full or substantial performance of this Contract; and no payment shall be construed to be an acceptance of any defective work or improper material.

The acceptance of Final Payment by the Contractor shall release the CITY, the BOARD, and the ENGINEER from any and all claims or liabilities on account of work performed by the Contractor under the Contract or any alterations thereof.

The Contractor shall record, on the set of contract documents maintained at the job site, deviations which have been made from the Contract Documents or approved shop drawings – including buried or concealed construction and utility features which are revealed during the course of construction. Special attention shall be given to recording the horizontal and vertical location of all buried utilities that differ from the locations indicated, or which were not indicated on the Contract Documents. Said record documents shall be supplemented by detailed sketches as necessary or directed, to indicate fully the work as actually constructed.

Requests for partial payments shall not be approved until the record documents are brought up to date. Also, request for final compensation shall not be approved until all the variations between the work as constructed and as originally shown in the Contract Documents have been properly recorded and delivered to the City, after approved by the Engineer.

[Add the following:].

7-3.2.1 Prompt Progress Payment to Subcontractors

Contractor shall comply with the requirements of Division 2, Part 1, Chapter 7, Section 7200 of the California Public Code.

The CONTRACTOR agrees to pay each subcontractor under this Agreement for satisfactory performance of its contract no later than 7 days from the receipt of each payment the CONTRACTOR receives from CITY.

The CONTRACTOR agrees further to release retainage payments to each subcontractor within 7 days after the retention payment is received by the CONTRACTOR.

Any delay or postponement of payment from the above referenced time frame may occur only for good cause following written approval of the CITY. Any violation of this provision shall subject the violating prime contractor or subcontractor to the penalties, sanctions and other remedies specified in Section 7108.5 of the Business and Professions Code. This clause applies to both DBE and non-DBE prime contractors and subcontractors.

City will be strictly monitoring the Contractor for prompt payment to all subcontractors.

[Add the following:].

7-3.2.2 Prompt Pay Monitoring and Enforcement of Progress Payments

The City of Costa Mesa will use the following monitoring and enforcement mechanisms to ensure that all subcontractors, including DBE's, are promptly paid.

- A. The City will strictly monitor the prime contractor or subcontractor(s) for prompt release of progress payments for all subcontracted work as follows:
 1. The effective date of release is the date the City releases the check to the prime contractor by mailing or hand delivery at the City of Costa Mesa (has to be requested in writing ahead of time).
 2. Prime contractor or subcontractor(s) to provide verification in writing that the subcontracts have been paid within 7 days or the time period agreed, from the effective date of release.
 3. City may contact subcontractor(s) to confirm receipt of progress payment amount and if it was received within 7 days or the time period agreed from the

effective date of release.

- B. If the prime contractor or subcontractor(s) is found to be in default of Federal or State Codes concerning prompt payment to subcontractors, City will enforce the following besides the disciplinary action, sanctions and penalties imposed per the codes:
1. City will withhold 150% of the monies due to the subcontractor(s) from the prime contractor's next progress payment.
 2. City may also elect to make the payment(s) directly to the subcontractor(s) without the prime contractor's approval for the remainder of the contract.

7-3.3 Delivered Materials

[Replace in its entirety with the following:].

The cost of materials and equipment delivered, but not incorporated in said work, will not be included in the progress payment estimate unless otherwise provided in these Specifications.

Materials delivered, but not in place, will not be classed as work done, except as otherwise provided in these Specifications.

All materials shall be nontoxic and shall not contain asbestos and hazardous substances as established by applicable laws.

7-3.4 Mobilization

[Replace in its entirety with the following:].

Mobilization shall consist of all preparatory work and operations. It shall include, but not be limited to, the movement of personnel, equipment, materials and incidentals to the project site necessary for work on the project. The mobilization shall include all other work and operations, which must be performed.

Mobilization shall also include the time, materials, and labor to move the necessary construction equipment to and from the job site and the project administration costs during the entire contract period.

This work shall include, but not be limited to protect-in-place and/or relocation of the facility to accommodate the construction of an improvement; including resetting curb drains through new curbing.

The Contractor shall provide supervisory personnel to keep the construction site in a safe condition and all other related work as required at all times. These requirements shall also apply to all non-working days during construction period. The Contractor is responsible for securing an adequate storage site for equipment and materials.

The Contractor shall have on the work site at all times, as his agent, a competent English speaking superintendent capable of reading and thoroughly understanding the plans, specifications, and other related documents.

7-3.4.1 Travel Route for Trucking and Equipment

Plans indicating the travel route for the Contractor's equipment movement in and out of the work site must be submitted concurrently with the Haul Route Plan (Section 2-5.4) to the ENGINEER at the pre-construction meeting for approval prior to commencement of any work. The travel route plans, which meet the City's requirements, will be approved and returned to the Contractor; otherwise, further revisions are required until they are acceptable to the City. The approved travel plans shall be strictly adhered to by the Contractor during all phases of the construction.

Any deviation from these requirements is not permitted. All the Contractor's operations will be ceased at once if the Contractor violates any of these requirements. No further payments will be made to the Contractor until problems are resolved according to the City's requirements.

7-3.4.2 Construction Sequence/Order of Work

In order to minimize the inconvenience to adjacent buildings, businesses, and facilities that will remain in operation, the contractor shall construct the project and sequence the work in such a manner as to minimize impacts to the ongoing operation of adjacent buildings, businesses, and facilities. The proposed and subsequently approved Construction Schedule will be reflective of this requirement.

7-4 PAYMENT FOR EXTRA WORK

7-4.2 Basis for Establishing Costs.

7-4.2.1 Labor

[Add the following:].

The compensation for employer's payments of payroll taxes; workers compensation insurance; liability insurance; health and welfare; pension; vacation; apprenticeship funds; other direct costs resulting from Federal, State, or local laws; and for assessments or benefits required by lawful collective bargaining agreements to be applied to the actual cost for wages shall be **23 percent** for regular time and overtime.

7-4.3 Markups

7-4.3.1 Work by the Contractor

[Replace in its entirety with the following:].

The allowance for overhead and profit to be added to the Contractor’s costs shall be as follows:

Labor:	20%
Materials:	15%
Contractor Owned Equipment	15%
Equipment Rental	10%*
Other Items and Expenditures	10%

To the sum of the costs and markups provided for in this section, 1 percent shall be added as compensation for bonding.

* Equipment Rental rates shall be based on the latest applicable Caltrans Equipment Rental Rates.

7-4.3.2 Work by a Subcontractor

[Replace in its entirety with the following:].

When all or any part of the extra work is performed by a Subcontractor, the markup established in 3-3.2.3(a) shall be applied to the Subcontractor’s actual cost of such work. A markup of (5) percent on subcontracted portions of added work may be added by the Contractor.

No markups will be allowed for second tier or higher subcontractors.

[Add the following:].

7-6 SUMMARY OF PUBLIC CONTRACT CODE § 9204

The following procedure will apply to any claims by the Contractor on the City:
A “claim” is a separate demand on the City by a contractor on a public works project and sent by registered mail or certified mail with return receipt requested, for one or more of the following:

- A time extension, including relief from penalties for delay
- Payment by the City of money damages under the terms of the contract
- Payment of an amount that is disputed by the City

Initial Review

The claim must be supported by appropriate documentation. The City has 45 days within which to review the claim and provide the contractor with a written statement identifying the disputed and undisputed portions of the claim. If the City does not issue a written statement, the claim is deemed rejected in its entirety. The City will pay any undisputed portion of the claim within 60 days of issuing the statement.

Meet & Confer

If the contractor disputes the City's written response, or if the City does not issue one, the contractor may request in writing an informal conference to meet and confer for possible settlement of the claim. The City will schedule the meet and confer conference within 30 days of this request and provide a written statement identifying the remaining disputed and undisputed portions of the claim within 10 business days of the meet and confer. The City will pay the undisputed portion within 60 days of issuing this statement.

Mediation

With respect to any disputed portion remaining after the meet and confer, the City and contractor will submit the matter to nonbinding mediation, agree to a mediator within 10 business days after issuing the written statement, and share mediation costs equally. If mediation is unsuccessful, then the terms of the public works agreement and applicable law will govern resolution of the dispute.

Miscellaneous Provisions

Amounts not paid by the City in a timely manner bear interest at 7% per annum. Subcontractors may submit claims via this procedure through the general contractor. The City and contractor may waive the requirement to mediate, but cannot otherwise waive these claim procedures.

SECTION E

[Add the following Section:].

PART 1.1 SPECIAL PROVISIONS

101-1 GENERAL

Additions/Modifications to Standard Specifications

The following additions are made to the latest edition of the "Standard Specifications for Public Works Construction" (The "Greenbook"), and the General Provisions stated within the "Standard Specifications" of this Project. Should there be a conflict between any of these provisions; the Special Provisions shall have precedence.

All work shall be performed in conformance with the latest edition of the Uniform Building Code as adopted by the City of Costa Mesa. The electrical, plumbing, and fire codes, and other regulations as adopted by the City of Costa Mesa Building Official shall apply to this project.

Where referenced in these specifications, the latest edition of the "City of Costa Mesa Standard Drawings" and the "Work Area Traffic Control Handbook (WATCH)" published by Building News, Inc., shall also apply.

Payment for compliance with the following provisions shall be included in the various bid items of work unless otherwise modified in the special provisions section. No additional compensation will be allowed.

If the item of work is identified within the Proposal section of these Specifications, then the following bid item descriptions will provide the corresponding bid item numbering within each corresponding section of the Standard Specifications under the Subsection entitled "Measurement and Payment" or "Payment". All other sections and subsections shall conform to the Standard Specifications unless modified herein.

The unit prices and lump sum amounts to be paid for under the bid items listed in the Proposal shall include full compensation for furnishing all labor, materials, tools, equipment and incidentals necessary for the completion of the work and for performing all work contemplated and embraced under the Contract, in accordance with the Plans and Contract Documents. This shall include the Contractor's costs involved with bonding, insurance, worker's compensation, overhead, financing, obtaining required permits and permit fees, mobilization, traffic control, public convenience and safety, protective barricading/fencing, sanitary facilities, storage of equipment and materials, security against theft and vandalism, project site maintenance, dust and runoff control, clean-up including all costs for compliance with the regulations of public agencies having jurisdiction, including Safety and Health Requirements of the California Division of Industrial Relations and the Occupational Safety and Health Administration (OSHA) of the U. S. Department of Labor, and all other items related to the work.

Payment for compliance with the following provisions shall be included in the various bid items of work unless otherwise modified in the special provisions section. No additional compensation will be allowed.

No separate payments will be made for any items that are not specifically set forth in the Bid Proposal. Payments for any such items are included in various bid items of work.

Costs arising from violations of regulations will be paid by the offending party to the extent that there will be no additional cost to the City.

Upon notice of award, the successful bidder may submit a schedule of values that breaks down lump sum bid items of work into separate operations to establish additional payment categories and line items of work to be completed by the Contractor. The schedule of values shall be based on the awarded bid items and may be requested by the City, or the Contractor. The schedule of values shall be provided by the Contractor for review by the City prior to commencement of the work.

Payment for unit price work shall be made for the actual quantities of Contract Items removed, constructed, or disposed of in accordance with the Plans and these Specifications. Measurement of Unit Price work shall be specified in the Standard Specifications, Section 7-1, "Measurement of Quantities for Unit Price Work." Payment for Lump Sum work shall be paid for at the price indicated in the Bid, in accordance with the Standard Specifications, Section 7-2, "Lump Sum Work."

Payment for all work shall be included in the various bid items. No additional compensation shall be made therefore. Work associated with each bid item shall include, but not be limited, to the bid descriptions set forth herein.

101-2 POLICE DEPARTMENT UNDERGROUND STORAGE TANK CLOSURE

101-2.1 General - Work to be Performed

The scope of work generally consists of providing environmental testing, utility investigation, structural assessment, geotechnical assessment, reporting, plans, permitting, and construction required to safely close the existing Police Department Underground Storage Tank.

The closure of the UST will be approached as an "abandon in place" project. **However, structural assessment and environmental testing may reveal unforeseen circumstances that could require additional remediation and the removal of the tank.**

The initial project approach will be to abandon the underground storage tank, in place and the unit prices and bid schedule include the following project scope of work:

- Provide engineered plans/documents, permits, and fees as required by Orange County Health Care Agency Environmental Health Division (OCHA) to permit and perform the work.
- Coordinate and obtain permits from the Orange County Fire Authority or local fire department and local Building Department. As well as the South Coast Air Quality Management District (SCAQMD).
- Complete environmental testing while tank is in place per approved sample plan as specified by the Orange County Health Care Agency (OCHCA), Environmental Health Division's "DRAFT -

Standard Operating Procedure for Closure in Place of an Underground Storage Tank”, Appendix “A1”; and as specified in the OCHCA, Environmental Health Division “Guidelines for the Removal of Underground Storage Tanks”, Appendix “A2”.

- Reference operating permit in Appendix “A3” and existing plans in Appendix “A4” as part of structural and geotechnical analysis/reports to develop OCHCA approved Tank closure plan.
- Provide assessments from structural engineer, environmental engineer, and geotechnical engineer that provide recommendation for Tank closure.
- Mobilize for project and have job staffed to allow for weekly progress meetings.
- Set temporary fencing and approved temporary traffic control as required.
- Sawcut, break, dismantle, excavate, remove, and dispose/stockpile materials above tank including but not limited to existing concrete walkway, existing risers, piping runs, top of tank, tank top equipment, and dirt.
- Excavate and shore around the underground tank as required. Perform SCAQMD Rule 1166 monitoring during excavation. Protect trenching and excavations throughout project.
- Safely stockpile and protect excavated material on site for re-use.
- **Abandon Tank** - Triple rinse with a OCHCA approved detergent and cleaning method to inert tank and certify clean.
- Backfill 6,000-gallon double wall fiberglass underground storage tank, with OCHCA approved slurry mix.
- Provide necessary environmental compliance, inspections, testing, borings, and an authorized tank closure report.
- Remove unused vent stack from the side of the building.
- Backfill the excavation with the existing backfill material and provide compact subgrade and finish grade.
- Remove testing equipment/facilities upon completion of environmental compliance.
- Form, dowel in #4 rebar to the existing concrete, and patch back any walkway concrete that was removed at the side of the building.
- Landscaping to match the existing parkway, shall replace where concrete was removed from the parkway above the tank.
- Provide close out package, and certified payroll records.
- Upon notice of award, the successful bidder shall provide a schedule of values, submittals, and comprehensive project schedule for review and approval by the City’s Public Services Department.

101-2.2 Measurement and Payment of Bid Items

BID ITEM NO. 1: MOBILIZATION AND DEMOBILIZATION

Contractor shall provide all labor, equipment, and materials for the construction of the specific improvements and repairs established with these specifications, that include but may not be limited to items listed in section 2-1 of the General Provisions and upon referencing the project documents hereon and in the project appendices. Mobilization shall be considered full compensation for obtaining all business licenses and permits, as required for the entire project, from all related agencies, including, but not limited to, utility companies, private and public agencies and the CITY; and complying with the requirements specified in those licenses and permits; coordination, field office facility, all required submittals specified within these Specifications, and incidentals necessary to perform all related items of work unless otherwise stated in these special provisions. Progress payments for the Mobilization and Demobilization bid item shall be paid for in accordance with the completion percentage of the Project to the Contractor and shall include the cost of such mobilization/demobilization and administration during the entire Contract period. No additional compensation will be allowed.

Mobilization shall include compliance with water and air quality laws; maintaining dust control at all times; furnishing all water required for the construction work; protection of utilities, survey monuments, trees, fences, walls, landscaping and other facilities.

Mobilization shall include all related "de-mobilization" costs, including the removal of any remaining Underground Service Alert (USA) utility markings or other construction paint markings, by means of wet sand blasting or other pre-approved method on the sidewalk, curb/gutter and pavement.

Mobilization shall include all work and related work shown on the plans or described in the contract documents, which is not compensated for in a specific bid item of work. This work shall include, but not be limited to protect-in-place and/or relocations of the facility to accommodate the construction of an improvement, and removal of existing planters, trees, shrubs, and bushes.

Contractor shall confine his operations and work area to the street right-of-way and is responsible for securing an adequate storage site for equipment and materials. No encroachment into private property will be permitted without prior written consent of the property owner and ENGINEER. Obtaining this consent will be the responsibility and at the cost of the Contractor. The Contractor shall provide supervisory personnel to keep the construction site in a safe condition at all times.

Contractor shall protect the existing pavement and shall not store equipment on the street. The location of any flat bed trucks used to store equipment is subject to review and approval by the City.

The Contractor shall submit a Construction Schedule at least ten (10) working days prior to commencing work. All revisions shall be completed within three (3) days after review by the City. The Contractor shall submit requests for changes in the schedule to the City for approval at least three (3) working days prior to performing any work.

Measurement and Payment for **Mobilization and Demobilization** shall be per Lump Sum (L.S.) price bid item for all work performed and shall include all project administration, labor, equipment, and materials as required to complete the contract work as described hereon.

No additional compensation will be allowed.

BID ITEM No. 2: PERMITTING

Contractor shall provide necessary plans, documents, labor, equipment, and materials to complete all permitting and coordinate all inspections as required by the Orange County Health Care Agency's (OCHCA) Environmental Health Division to perform the work in the contract. The Contractor shall also obtain permits, provide documentation, applications, and coordinate any inspections from the City's Fire Department, the City's Building & Safety Division, and the South Coast Air Quality Management District (SCAQMD).

Measurement and Payment for **Permitting** shall be per Lump Sum (L.S.) price bid item for all permitting, inspections, coordination, labor, equipment, and materials required to complete the contract work described hereon.

No additional compensation will be allowed.

BID ITEM No. 3: ENVIRONMENTAL COMPLIANCE

Contractor shall conduct all testing and environmental engineering related to Bid Item No. 3 while the tank is still in place. The engineered environmental testing report and soil sample analysis that is conducted as part of the environmental compliance shall be based on testing and soil samples collected by the contractor. Contractor shall collect up to (8)-soil samples to be used for soil contamination analysis.

Contractor shall provide/obtain necessary environmental compliance, including but not limited to plans, sampling, testing, reporting, inspections, certifications, tank closure reports, labor, equipment, and materials to satisfy all environmental requirements as set forth by the Orange County Health Care Agency (OCHCA), Environmental Health Division's "Standard Operating Procedure for Closure in Place of an Underground Storage Tank" (Exhibit "A1"), and as specified in the OCHCA, Environmental Health Division "Guidelines for the Removal of Underground Storage Tanks" (Exhibit "A2"). Contractor shall provide updates regarding the Environmental Compliance by scheduling bi-weekly progress meetings with the ENGINEER.

Measurement and Payment for **Environmental Compliance** shall be per Lump Sum (L.S.) price bid item for all environmental sampling, testing, reporting, coordination, labor, equipment, and materials required to complete the contract work described hereon.

No additional compensation will be allowed.

BID ITEM No. 4: SITE INVESTIGATIONS AND UTILITY LOCATION

Contractor shall conduct all testing and investigations related to Bid Item No. 4 while the tank is still in place and provide both the geotechnical engineer's report and a structural engineer's report to evaluate existing conditions. Testing conducted by the contractor for the engineering analysis may include exploratory borings, providing utility locations via potholing/GPR (Ground Penetrating Radar), as well as collecting soil samples to be used for soil mechanics analysis. Contractor shall provide updates regarding the Site Investigations and Utility Location by scheduling bi-weekly progress meetings with the ENGINEER.

Reference operating permit in Appendix "A3" and existing plans in Appendix "A4" as part of structural and geotechnical analysis/reports and to develop OCHCA approved tank closure plan.

Upon review of the geotechnical and structural engineering reports City shall confirm and finalize the process by which the tank closure will take place and Contractor shall coordinate tank closure per the OCHCA regulations.

Measurement and Payment for **Site Investigation and Utility Location** shall be per Lump Sum (L.S.) price bid item for all geotechnical and structural engineering, engineering reports, utility investigations, utility reporting, OCHCA coordination, labor, equipment, and materials required to complete the contract work described hereon.

No additional compensation will be allowed.

BID ITEM No. 5: SITE PREP AND EXCAVATIONS

Site prep includes saw cutting, breaking, removing, and disposing of the existing concrete on site adjacent to the building, concrete curb, gutter, sidewalks in the public right-of-way, and materials above and around the tank; as well as dismantling and disposing of all removed risers, piping runs, and tank top equipment. The existing vent stack that is no longer in operation shall be removed from the building and disposed of by the Contractor as part of this work.

All excavations shall be performed in conformance with SCAQMD Rule 1166 monitoring and contractor shall protect all trenching and safely stockpile and protect excavated material on site for testing and possible re-use until it can be confirmed the material is safe for export and disposal by Contractor.

Measurement and Payment for **Site Prep** and Excavations shall be per Lump Sum (L.S.) price bid item for all site prep, excavation, stockpile, removals, demolition, disposal of materials, labor, equipment, and materials required to complete the contract work described hereon.

No additional compensation will be allowed.

BID ITEM No. 6: ABANDON TANK IN PLACE

Contractor shall triple rinse with an OCHCA approved detergent and method, make inert, certify clean, and backfill 6,000 gallon double wall underground storage tank as required by the OCHCA, Environmental Health Division per "Draft Guidelines for Closure in Place of an Underground Storage Tank" per appendix "A1".

As part of the abandonment Contractor shall disconnect, remove, transport, and safely dispose of all the the associated tank piping per OCHCA "Guidelines for the Removal of Underground Storage Tanks", Appendix "A2".

All necessary environmental compliance, inspections, testing, borings, and authorized tank closure reports shall be obtained and coordinated by the Contractor as part of Bid Item No.3.

Measurement and Payment for **Abandon Tank In Place** shall be per Lump Sum (L.S.) price bid item for all cleaning, slurry backfill, hazardous material disposal, labor, equipment, and materials required to complete the contract work described hereon.

No additional compensation will be allowed.

BID ITEM No. 7: BACKFILL

Contractor shall backfill and compact the site with existing backfill material and provide compaction reports and Crushed Miscellaneous Base (CMB) as required to prepare the site for finish grade concrete and landscaping.

Measurement and Payment for **Backfill** shall be per Lump Sum (L.S.) price bid item for all backfill, compaction, engineered compaction reports, CMB, labor, equipment, and materials required to complete the contract work described hereon.

No additional compensation will be allowed.

BID ITEM No. 8: *RESTORE SITE*

Contractor shall form walkway concrete, dowel in #4 rebar to existing concrete, pour, and finish all walkway concrete that was removed from alongside the Police Department Building. Where concrete was removed from directly above the tank, in the parkway, grades shall be prepared, and grass parkway landscaping to match existing parkway landscaping shall be installed. Contractor shall modify existing irrigation system to include added parkway landscaping. Any sidewalk, curb & gutter, or damaged facilities in the public right-of-way shall be replaced, in kind, per City/Agency Standards. As required, where building vent stack was removed, the existing building shall be finished to match adjacent building finish.

Measurement and Payment for **Restore Site** shall be per Lump Sum (L.S.) price bid item for all grading, formwork construction, CMB, rebar, concrete placement, concrete finishing, landscaping, irrigation, general site repairs, labor, equipment, and materials required to complete the contract work described hereon.

No additional compensation will be allowed.

BID ITEM No. 9: ALLOWANCES

The Contractor acknowledges that this bid item will only be used at the discretion of the ENGINEER. The allowance for this line item is as shown within the Proposal Section of these Specifications.

At the direction of the ENGINEER, Contractor shall provide pricing, documentation, and justification for all labor, equipment, and materials for any additional work requested beyond the base Scope of Work established within these specifications.

Upon review of pricing, and at the direction of the ENGINEER, the Contractor shall provide labor, equipment, and materials for the additionally priced scope beyond the base Scope of Work established within the Project Plans and Specifications.

The Police Department Underground Storage Tank Closure will be approached as an "abandon in place" project. OCHCA protocols, structural assessment, utility investigations, and environmental testing may reveal unforeseen circumstances that require additional soil remediation that may ultimately require the removal of the underground storage tank (UST) and warrant additional environmental testing.

The Contractor acknowledges this bid item will be used at the discretion of the ENGINEER for the following unforeseen circumstances.

- Tank Removal and Disposal
- Placement and removal of engineered shoring for tank removal.

- Mitigating unforeseen structural deficiency.
- Mitigating unforeseen hazardous materials
- Mitigating unsuitable materials/soils
- Mitigating unmarked utilities
- Mitigating any other unknown issues and circumstances

Measurement and Payment for "Additional Work Items" shall be paid per Forced Account (F.A.) for all work performed pursuant to Section 7-4.2 of these specifications and shall include all labor, equipment and materials as required to complete the work as directed by the Engineer.

101-3 ALLOWANCES – ADDITIONAL WORK ITEMS

101-3.1 General

This work item entails work beyond the Scope of Work established within the Specifications, and Standard Specifications as directed by the ENGINEER with a specified Contract allowance

Allowance to be included in the total bid amount as identified as follows. Use of the allowance will be at the sole discretion of the City and must be authorized in writing at the discretion of the City. Any money used from the project allowance will be authorized via an Allowance Disbursement Form at the City's sole discretion. Any amount of money remaining in the Allowance line item upon completion of the Project will be deducted from the Contract by Deductive Change Order for the full amount(s) remaining therein. The Contractor has no beneficial interest in, and/or claim to, the Allowances and hereby disclaims any and all such interests.

Additional work items include work that will only be used at the discretion of the ENGINEER. At the discretion of the ENGINEER, the Contractor shall provide all labor, tools, equipment, materials and incidentals for the extra work beyond the scope of work established within the Contract documents. Work may include, but not be limited to, delivery of additional newsletters; disposal of materials, potholing, furnishing and installation of informational signs, and related work, and will only be performed, if required, and approved by the ENGINEER. The Contractor acknowledges that this allowance will only be used at the discretion of the City. Contractor shall be paid at force account or at agreed prices for all work performed within this allowance.

SECTION F

MODIFICATIONS TO STANDARD SPECIFICATIONS

PART 2 CONSTRUCTION MATERIALS (No Additions or Modifications)

PART 3 CONSTRUCTION METHODS (No Additions or Modifications)

PART 4 EXISTING IMPROVEMENTS

SECTION 400 – PROTECTION AND RESTORATION

400-1 GENERAL

[Add the following:].

400-1.1 DRAINAGE CONTROL : RESPONSIBILITES

The CONTRACTOR shall be responsible for any damage to any portion of the work occasioned by failure to provide proper drainage control prior to the completion and acceptance of the work.

400-1.2 DRAINAGE CONTROL : EXCAVATION DEWATERING REQUIREMENTS

Unless otherwise directed in these specifications, the CONTRACTOR shall provide and maintain ample means and devices with which to promptly remove and properly dispose of water entering the excavations or other parts of the work at all times during construction. Dewatering shall be accomplished by methods which will ensure a dry excavation and preservation of the final lines and grades of the bottoms of excavations. The methods may include sump pumps, deep wells, well points, suitable rock or gravel placed below the required bedding for draining and pumping purposes, temporary pipelines, and other means.

Standby pumping equipment shall be on the job site. A minimum of one standby unit shall be available for immediate installation should any well unit fail. The design and installation of well points or deep wells shall be suitable for the accomplishment of the work. Drawings or details indicating the proposed dewatering system shall be submitted to the CITY for review.

The CONTRACTOR shall dispose of the water from the work in a suitable manner without damage to adjacent property.

Conveyance of the water shall be such as to not interfere with traffic flow or treatment facilities operations. No water shall be drained into work built or under construction without prior consent of the ENGINEER.

Water drained from any facilities shall comply with local agency and health department requirements including declorinating any water prior to discharge.

Water shall be disposed of in such a manner as not to be a menace to the public health and such disposal shall be performed in accordance with Environmental Protection Agency and State Water Quality Control Board standards (NPDES permit). Any testing and reports required under NPDES permit shall be performed by the CONTRACTOR and submitted to the appropriate agency for approval at no additional cost to the CITY.

400-1.3 CLEAN-UP AND DUST CONTROL

All surplus materials and waste debris shall be removed from the site of the work within five (5) days after completion of the work causing the surplus materials.

Contractor shall utilized misting or water spray as means of dust control during construction.

Failure of the CONTRACTOR to comply with the ENGINEER'S clean-up dust control orders may result in an order to suspend work until the condition is corrected and, after giving notice to the CONTRACTOR, the ENGINEER may order the condition corrected by others. All costs thus incurred shall be deducted from the amount to be paid to CONTRACTOR. No additional compensation will be allowed as a result of such suspension.

No separate payment will be made for any work performed nor material used to control dust resulting from CONTRACTOR's performance of the work or from public traffic, either inside or outside the right-of-way. Full compensation for such dust control will be considered to be included in the prices paid for the various items of work involved.

SECTION 402 – UTILITIES

402-1 LOCATION

402-1.1 General

[Add the following:].

Locations of utilities shown on plans are approximate only and are based on a search of available records.

Attention is directed to the possibility of utility mains or laterals within the project limits. The CONTRACTOR shall have the locations of the various utility facilities within reconstruction areas marked on the surface prior to construction and protect them during the removal and reconstruction procedures. The CONTRACTOR shall contact the City Transportation Services Department to locate traffic signal conduit within the reconstruction areas.

Prior to commencing any other work, CONTRACTOR shall carefully excavate and determine precise locations and depths of all utilities, including service connections, shown on the plans and marked in the field, which may affect or be affected by CONTRACTOR's operations. This work shall be done in accordance with Section 402-1.1 of the Standard Specifications. CONTRACTOR shall not be compensated for any delays or extra work brought about by his failure to perform the above-mentioned work. CONTRACTOR shall be responsible for any damage to existing utilities shown on the plans pursuant to its location operations as required under this subsection of the Standard Specifications.

Upon completion of the Project, the CONTRACTOR shall be required to remove, to the satisfaction of the ENGINEER, all utility locator markings and utility tie-out paint markings that either the CONTRACTOR, the CITY or utility companies make during the course of the work from the surfaces of sidewalks, driveway approaches, curb and gutters, using the removal method acceptable to the ENGINEER. Any damage to the existing improvements due to CONTRACTOR'S removal operation, shall be included in the various applicable items of work, and no additional compensation will be allowed therefor.

The CONTRACTOR shall notify owners of the utility companies at least two (2) working days in advance of any work (See Subsection 402-4 of these Special Provisions for utility contact information).

402-1.2 Payment

[Replace with the following:].

Payment for utility location by the CONTRACTOR shall be included in the bid prices for the various items of work requiring utility location and no further compensation will be allowed.

402-2 PROTECTION

[Add the following:].

The CONTRACTOR shall be responsible for protecting and supporting all existing utilities and maintaining the location of and access to all gate valves during construction. When damage to existing utilities is caused by the CONTRACTOR's operations, the CONTRACTOR shall, at his expense, repair or replace damaged facilities promptly, in accordance with all applicable sections of the Standard Specifications and the standards of each affected utility. Should the CONTRACTOR fail to perform the required repairs or replacements, the cost of performing such repairs or replacement by others shall be deducted from any monies due or to become due the CONTRACTOR.

402-2.1 Payment

Payment for utility protection by the CONTRACTOR shall be included in the bid prices for the various items of work requiring utility protection and no further compensation will be allowed.

402-4 RELOCATION

[Add the following:].

Any miscellaneous utilities to be relocated by the CONTRACTOR, as indicated on the Plans, shall be relocated in a workmanlike manner, and all such work shall be done only at such times which are acceptable to the utility owner. The CONTRACTOR shall schedule its relocation work in cooperation with the utility owner and shall be responsible for any costs resulting from the CONTRACTOR's failure to do the work at times which are acceptable to the owner. The CONTRACTOR shall notify owners of the following companies at least two (2) working days in advance of any work:

<p>AT&T (right-of-way) Valentina Gipson 3939 E Coronado St, Rm 2030 Anaheim, CA 92807 (o) 714-618-9132 Email: vk3921@att.com</p>	<p>Cost Mesa Sanitary District Javier Ochiqui, Management Analyst 290 Paularino Avenue Costa Mesa, CA 92626 (o) 949-645-8400 Email: jochiqui@cmsdca.gov</p>
<p>AT&T Rhonda Clary-Byers (engineer for Costa Mesa) or Doug DiPaolo 3939 E. Coronado St. Anaheim, CA 92807 (o) 714-618-9116 (o) 714-618-9125 Email: rc1315@att.com Email: dd2634@att.com</p>	<p>Cost Mesa Sanitary District Marc Esquer, District Engineer 290 Paularino Avenue Costa Mesa, CA 92626 (o) 949-645-8400 Email: mesquer@cmsdca.gov</p>
<p>Mesa Water District Phil Lauri, Assistant General Manager 1965 Placentia Ave. (inter-office mail okay) Costa Mesa, CA 92627 (o) 949-207-5449 (c) 949-631-1200 (24-hour) Email: phill@mesawater.org</p>	<p>Mesa Water District Mark Pelka, Engineer 1965 Placentia Ave. (inter-office mail okay) Costa Mesa, CA 92627 (o) 949-207-5449 (c) 949-631-1200 (24-hour) Email: MarkP@mesawater.org</p>
<p>Mpower Communications, Inc. Mark Denning 2698 White Road Irvine, CA 92614 (o) 949-864-0296 (c) 949-547-6455 Email: mdenning@telepacific.com</p>	<p>Costa Mesa Sanitation District Nabila Guzmán, Construction Notices 290 Paularino Avenue Costa Mesa, CA 92626 (o) 949-645-8400, ext. 230 Email: nguzman@cmsdca.gov</p>
<p>Orange County Sanitation District (OCSD) Rudy Davila P.O. Box 8127 Fountain Valley, CA 92728 (o) 714-593-7348 (c) 714-593-3301 (24-hour) Email: RDavila@ocsd.com</p>	<p>Orange County Water District (OCWD) Chris Olsen P.O. Box 8300 Fountain Valley, CA 92728 (o) 714-378-3200 (c) 714-378-3240 (24-hour) Email: colsen@ocwd.com Email: utilityrequest@ocwd.com</p>

<p>Irvine Regional Water District Brad Jackson (Area Construction Inspector) 15600 Sand Canyon Ave. Irvine, CA 92618 (o) 949-632-0627 (p) 949-729-7300 (24-hour) Email: jackson@irwd.com</p>	<p>CA Regional Water Quality – Santa Ana Region Mark Smythe 3737 Main St., Suite 500 Riverside, CA 92501 (o) 951-782-4130 (c) 951-543-8523 Email: msmythe@waterboards.ca.gov</p>
<p>Irvine Ranch Water Dist. – Development Services* Christian Kessler, P.E. 15600 Sand Canyon Ave. Irvine, CA 92618 (o) 949-453-5300 (p) 949-453-5441 Email: kessler@irwd.com <i>*utility requests</i></p>	<p>Irvine Regional Water District Kelly Lew 15600 Sand Canyon Ave. Irvine, CA 92618 (o) 949-453-5586 (p) 949-729-7300 (24-hour) Email: lew@irwd.com</p>
<p>Metropolitan Water District of So. California Civil Engineering Substructures Section Shoreh Zareh P.O. Box 54153 Los Angeles, CA 90054 (o) 213-217-7474 (c) 626-844-5610 (24-hour) Email: szareh@mwdh2o.com</p> <p>Metropolitan Water District of So. California Civil Engineering Substructures Section Kieran Callanan P.O. Box 54153 Los Angeles, CA 90054 (o) 213-217-7474 (c) 626-844-5610 (24-hour) Email: kcallanan@mwdh2o.com</p>	<p>SCE (Senior Compliance) Susan Morgan (o) 909-835-7527 (c) 909-835-7527</p> <p>SCE (Service Planner – Orange Coast S/C) Mónica Balderas 7333 Bolsa Ave. Westminster, CA 92683 (o) 714-329-2778 Email: monica.balderas@sce.com</p> <p>Email: susan.morgan@sce.com <i>*No pre-construction meeting notices BUT Susan Morgan and Mónica Balderas would like to attend all UTILITY MEETINGS and be made aware of any fee schedule changes.</i></p>
<p>SCE (Base Maps) Kimberly Gurule 1444 E. McFadden Ave., Bldg. "D" Santa Ana, CA 92705 (o) 714-796-9932 Email: maprequests@sce.com <i>*No pre-construction meeting notices to this address – map requests ONLY.</i></p>	<p>SCE (Service Planner 1 – Orange Coast S/C) Nick Mukanos 7333 Bolsa Ave. Westminster, CA 92683 (o) 714-895-0210 Email: nick.mukanos@sce.com</p>
<p>SCE (Utility Notice Requests) Kasy Chapman 7333 Bolsa Ave. Westminster, CA 92683 (o) 714-895-0109 (c) 800-611-1911 (24-hour) Email: kasey.chapman@sce.com</p>	<p>SCE (Service Planner 2– Orange Coast S/C) Damon Humphrey 7333 Bolsa Ave. Westminster, CA 92683 (o) 714-895-0534 Email: damon.humphrey@sce.com</p>
<p>Southern California Gas Co. (Transmission) P.O. Box 2300 Chatsworth, CA 91313-2300 (o) 818-701-4546 Email: SoCalGasTransmissionUtilityRequest@semprautilities.com</p>	<p>*Reminder* After facilities are identified on the plans, send the plans to Gail Gardner, and she will forward to SCE's planning department. Send to: gail.gardner@sce.com</p>

<p>Southern California Gas Co. Alfredo Gutierrez, franchise planner (o) 213-231-7515 Email: Agutierrez9@socalgas.com</p>	<p>Southern California Gas Co. Wilson Baldelomar P.O. Box 3334, SC8321 Anaheim, CA 92803 (o) 714-634-5091 (p) 800-603-7060 (24-hour) Email: wbaldelomar@semprautilities.com</p>
<p>XO Communications Matt Bergine Engineer IV Specialist-Network Engineering & Operations (o) 949-417-7841 (c) 714-822-6207 Email: matt.bergine@verizon.com</p>	<p>XO Communications Switchboard (o) 703-547-2000</p>
<p>Charter Communications Don Simons Construction Manager, Zone 8 7142 Chapman Ave. Garden Grove, CA 92841 (o) 714-591-4871 Email: don.simons@charter.com</p> <p>Charter Communications Utility Research Requests E-mail: DL-SOCAL-CHARTERENGINEERING@CHARTER.COM</p>	<p>Verizon Business Investigations 2400 N. Glenville Dr. Richardson, TX 75082 (o) 972-729-6016 (o) 469-886-4238 Email: investigations@verizon.com *2nd Email: chuck.czumak@verizon.com Contact Verizon Business for issues involving: --- Brooks Fiber Properties, Inc. --- MCImetro Access Transmission Svcs. --- MCI Telecommunications Svcs --- MFS Telecom, Inc. --- SoutherNet, Inc. / WorldComNetwork Svcs. --- Intermedia Communications, Inc. --- XO Communications</p>
<p>Newport-Mesa Unified School District Víctor Garza (o) 714-424-5080 Email: vgarza@nmusd.us</p>	<p>Newport-Mesa Unified School District Tim Marsh, Administrative Director, Facilities Support Svcs. (o) 714-4247527 Email: tmarsh@nmusd.us Newport-Mesa Unified School District Mary Gray Email: mgray@nmusd.us</p>
<p>DIGALERT.ORG (24-HR) 811 2 days before digging.</p>	<p>Kinder Morgan Jordan Neuner (o) 310-628-4350 Email: jordan_neuner@kindermorgan.com Karly Payne, Administrative Assistant (o) 714-560-4604 Email: karly_payne@kindermorgan.com</p>

Where existing utility main lines and conduits (excluding sewer main lines) and all utility service lines (excluding sewer laterals) are to be relocated or declared abandoned by the affected utility companies, the CONTRACTOR shall be responsible for contacting the respective utility representatives for coordinating the relocations and for determining the abandonments. The CONTRACTOR shall proceed with excavation in such a manner that will allow utility companies adequate and reasonable time to relocate service lines. The CONTRACTOR shall not be compensated for any delays caused by failure to coordinate the above work with utility companies.

PART 5
PIPELINE SYSTEM REHABILITATION
(No Addtions or Modifications)

PART 6
TEMPORARY TRAFFIC CONTROL

SECTION 600 – ACCESS

600-1 GENERAL

[Add the following:].

600-1.1 NOTIFICATION AND ACCESS

Prior to restricting normal access from public street to adjacent properties, the CONTRACTOR shall notify each property owner or owner's agent, informing them of the nature of the access restriction and the approximate duration of the restriction. The CONTRACTOR shall make every effort possible to minimize such restrictions.

Deliveries shall be conducted with appropriate flagmen and traffic controls.

Trenches left open overnight shall be bridged in a safe and acceptable manner at all driveways and walkways to provide safe access.

A minimum of one four (4) foot wide pedestrian walkway shall be maintained and safely delineated along each public street and through areas accessibile to the general public at all times during construction.

PART 7
STREET LIGHTING AND TRAFFIC SIGNAL SYSTEMS
(No Addtions or Modifications)

PART 8
LANDSCAPING AND IRRIGATION
(No Addtions or Modifications)

SECTION G

APPENDIX "A1"

Orange County Health Care Agency (OCHCA), Environmental Health Division

**DRAFT - Standard Operating Procedure for Closure in Place of an
Underground Storage Tank**



County of Orange, Health Care Agency, Environmental Health
1241 E. Dyer Rd., Ste. 120., Santa Ana, CA 92705
(714) 433-6000

Standard Operating Procedure

Closure in Place of an Underground Storage Tank

These guidelines apply to the owner of an underground storage tank (UST) subject to the permanent closure requirements of the California Code of Regulations (CCR) Title 23, Division 3, Chapter 16, Underground Storage Tank Regulations, Article 7. Closure Requirements and their agents, who are closing a UST in place.

1. Obtain written approval for closure in place from the Orange County Fire Authority or local fire department and City Building Department prior to initiating a closure in place application with Environmental Health.
2. Submit a completed Facility Modification Application to Environmental Health. Applications may be obtained in person at the address provided below, or by calling Environmental Health at (714) 433-6000. The application should be submitted at least 30 calendar days prior to the expected date of the UST closure activity. The following must be submitted with the application:
 - a. A copy of a letter of approval from the Orange County Fire Authority or local fire department and City Building Department, and
 - b. Four (4) sets of closure plans. Closure plans must include:
 - i. A site location map,
 - ii. A plot plan that:
 - Shows existing structures, utilities and all existing USTs and associated piping,
 - Identifies those USTs to be closed in place,
 - Clearly identifies the entire length of any piping proposed for closure in place, and
 - Includes the size of the USTs to be closed and the types of hazardous substances that have been stored in them.
 - iii. A sampling plan that meets the requirements of the California Code of Regulations (CCR), Title 23, Division 3, Chapter 16, Article 7. Closure Requirements, Section 2672 (d), including the following:
 - Proposed locations of borings,
 - Boring method (e.g., hollow stem auger, direct push, etc.),
 - Sampling collection protocol,
 - Number of samples, and
 - Sampling intervals and depth.

Note: Where directed by Environmental Health, the borings drilled for UST closure are also to confirm the depth to groundwater. If the depth to groundwater is less than 30 feet from the bottom of the UST, then a groundwater investigation will be required.

3. The applicant must apply for and obtain appropriate permits from the Orange County Fire Authority or local fire department, County Planning and Development Services Department or city building department, and the South Coast Air Quality Management District (SCAQMD).
4. Once the closure plans are approved and appropriate permits issued, the applicant is responsible for scheduling an onsite inspection with Environmental Health and a concurrent inspection with the Orange County Fire Authority or local fire department for inspection of the UST closure and oversight of soil sampling (see Section 6 below regarding soil sampling). To schedule an appointment with Environmental Health's Hazardous Materials Mitigation Section call a minimum of 48 hours prior to the desired appointment.
5. When closing a UST in place, the owner of the UST must comply with applicable provisions of the CCR Section 2672 (b) & (c) which include the following:
 - a. All residual liquid, solids, or sludges in the UST shall be removed and disposed of as hazardous waste or recyclable material;
 - b. The UST shall be completely filled with an inert solid approved by the Orange County Fire Authority or local fire department;
 - c. If the UST(s) contained a hazardous substance that could produce flammable vapors at standard temperature and pressure, then the UST shall be inerted to levels that shall preclude explosion or to such lower vapor levels as may be required by the Orange County Fire Authority or local fire department. (Note: A representative from the Orange County Fire Authority or local fire department must be present prior to initiating this procedure.), and;
 - d. All piping associated with the UST closure shall be removed and disposed unless its removal may damage significant structures, or there is other piping presently being used and contained in the same trench, in which case, the piping to be closed shall be emptied of all contents and capped.
6. Per CCR Section 2651 (d), the owner of the UST must demonstrate upon closure that no unauthorized release has occurred. This demonstration is based on sensory observations, monitoring equipment readings, soil sample analysis and/or water sample analysis. Sample collection points are to be determined as follows:
 - a. Environmental Health staff must be onsite to observe pipeline conditions and direct sampling in trenches where pipelines are to be removed. The area beneath the UST(s) to be closed in place and any associated piping to be closed in place must be assessed for an unauthorized release through the placement of borings and soil sampling approved in the sampling plan. Environmental Health staff must be onsite to oversee the placement of the borings and sample collection;
 - b. Samples are to be collected, handled and analyzed per CCR Section 2649 and as indicated below:

- i. Sample collection activities are to be performed by staff provided by the project consultant or the laboratory doing the sample analysis. The laboratory doing the sample analysis or the project consultant must provide the sample collection supplies required to facilitate the approved sampling protocol. A cooler or ice chest with ice is required to be present onsite so that the samples may be chilled immediately after sampling. When a sample is collected, an identifying label should be attached and the sample placed in a plastic bag where needed to avoid water damage to the label;
 - ii. The samples should be transported, per arrangements made by the tank owner, to a State Certified Laboratory immediately after sampling accompanied by the Chain of Custody form provided by Environmental Health. The receiving laboratory is to indicate on the Chain of Custody form in the designated laboratory section whether the samples were received in a chilled state and whether County seals were intact upon arrival; and,
 - iii. Samples collected at diesel or gasoline storage sites must be analyzed by an appropriate method for total petroleum hydrocarbons [TPH (GC/FID)] or total purgeable petroleum hydrocarbons [TPPH (GC/MS)] as diesel and/or gasoline, and by EPA Method 8260B to identify benzene, toluene, ethylbenzene, total xylenes (BTEX), Methyl Tertiary Butyl Ether (MTBE) and all other fuel oxygenates. Samples collected at waste oil storage sites must be analyzed for total recoverable petroleum hydrocarbons (TRPH) using EPA Method 1664, for full scan VOCs including BTEX, MTBE and all other fuel oxygenates, and chlorinated solvents by EPA Method 8260B, and for polycyclic aromatic hydrocarbons using EPA Method 8310 or 8270C (SIM Mode).
7. The detection of a reportable unauthorized release, based on field observations and/or the results of the soil and groundwater sample analysis, shall require compliance with the reporting requirements of CCR Section 2652 and the initial abatement and corrective action requirements of Articles 5 and 11 of Title 23, Division 3, Chapter 16, CCR.
8. Documentation required to be forwarded to this Agency includes:
 - a. Copies, signed by the receiving State permitted facility, of all Uniform Hazardous Waste Manifests used to transport the residual or rinseate liquid, solids, or sludge waste removed from the tanks; and
 - b. Original (wet) copies of the laboratory analytical report and the white copy of the OCHCA Chain of Custody form sent with the samples to the laboratory – with all required information completed by the laboratory.

Where the above requirements are successfully completed and an unauthorized release requiring further action is not discovered, a completion of a UST closure letter will be issued to the UST owner by Environmental Health. Should an unauthorized release be discovered, Environmental Health's Site Mitigation Section will open a UST cleanup case and, upon satisfactory completion of the required corrective action, a letter of remedial action completion will be issued.

If you have any questions or need additional information, please contact Environmental Health at (714) 433-6000.

SECTION G

APPENDIX "A2"

Orange County Health Care Agency (OCHCA), Environmental Health Division

Guidelines for the Removal of Underground Storage Tanks



REGULATORY/ MEDICAL HEALTH SERVICES
ENVIRONMENTAL HEALTH
Guidelines For The Removal Of
Underground Storage Tanks

These guidelines apply to the owner of an underground storage tank (UST) subject to the permanent closure requirements of the California Code of Regulations, Title 23, Division 3, Chapter 16, Underground Storage Tank Regulations, Article 7, Closure Requirements, and their agents, who are removing a UST and/or its associated piping.

1. Obtain a Facility Modification Application from Orange County Health Care Agency (OCHCA) Environmental Health. Applications may be obtained in person at the address provided below, or by calling Environmental Health at (714) 433-6000, or downloaded from the following website: <http://occupainfo.com/forms>.
2. At least 30 calendar days prior to the expected UST removal date, submit a completed Facility Modification Application, four sets of plans (drawing size not to exceed 11x17 inches) and a closure fee to Environmental Health at the office address given below. Plans must include:
 - a. A site location map, tank information/details, and
 - b. A plot plan that:
 - i. Identifies site location, inclusive of cross streets and a North arrow,
 - ii. Shows existing structures, utilities, and all existing USTs and associated piping,
 - iii. Identifies the USTs and/or piping to be removed,
 - iv. Clearly identifies the entire length of piping proposed for closure in place, if appropriate, See Section 7 (c) below for a description of piping that may be closed in place, and
 - v. Includes the size of the USTs to be removed and the types of hazardous substances that have been stored in the USTs.
3. Obtain closure and/or excavation permits from the appropriate agencies such as the County Planning and Development Services Department or city building department, the Orange County Fire Authority or local fire department and the South Coast Air Quality Management District (AQMD).
4. Submit a copy of the Hazardous Substance Removal Certification issued to the contractor performing the removal work. Section 7058.7 (e) of the Business and Professions Code states "A contractor may not install or remove a UST unless the contractor has passed the hazardous substance certification examination developed pursuant to this section." A contractor who is not certified may bid on or contract for the removal of a UST, if the work is performed by a contractor who is certified.
5. Schedule a UST removal inspection with Environmental Health's Hazardous Materials Mitigation Section. Environmental Health staff must be onsite to observe the condition of the UST(s) during removal and direct sampling to determine whether a reportable unauthorized release has occurred. Provide at least 48-hour notice to Environmental Health when scheduling an onsite inspection. A concurrent inspection must be scheduled with the Orange County Fire Authority or local fire department, which must also be represented at the UST removal. Alternate accommodations must be made in advance of field activities if Fire personnel decline the opportunity to be onsite during tank removal activities.

6. When removing a UST system and/or its piping, the owner of the UST(s) must comply with applicable provisions of the California Code of Regulations (CCR) Division 3, Chapter 16, Article 7, Closure Requirements. These include provisions of Section 2672 (b) & (c) which including the following:
 - a. All residual liquid, solids, or sludge from the UST and/or its piping shall be removed and handled as hazardous waste or recyclable material;
 - b. If the UST to be removed contained a hazardous substance that could produce flammable vapors at standard temperature and pressure, then the USTs shall be inerted to levels that shall preclude explosion or to such lower vapor levels as may be required by the Orange County Fire Authority or local fire department. (Note: A representative from the Orange County Fire Authority or local fire department must be present prior to initiating this procedure.); and,
 - c. The UST and/or its associated piping shall be removed and disposed. Where removal of piping might damage structures or other in use piping is contained in a common trench, that piping may be closed in place after being emptied of all contents and capped.
7. Per CCR Section 2651 (d), the owner of a UST must demonstrate upon closure that no unauthorized release has occurred. This demonstration shall be based on sensory observations, monitoring equipment readings, soil sample analysis and/or water sample analysis. Sample collection activities are to be performed by staff provided by the project consultant or the laboratory doing the sample analysis.
 - a. Samples must be obtained from the excavations of any UST and/or piping removed. Regulations require two samples, one at each end of each UST removed and samples for each 20 linear feet of pipe trenching. Where closure in place of piping is necessary and where soil samples cannot otherwise be obtained, soil borings placed near the piping trench may be required. Further, in an effort to obtain data required for evaluation under State Water Board Resolution No. 2012-0062, sidewall samples from depths between 0-10 feet below ground surface may be required.
 - b. Samples are to be collected, handled and analyzed at the owner's expense per CCR Section 2649 and as indicated below:
 - i. The laboratory doing the sample analysis or the project consultant must provide adequate supplies of thin-walled stainless steel or brass cylinder sample holders with fitted polyethylene caps, labels, plastic bags and Teflon sheets. A cooler or ice chest with ice is also required to be onsite;
 - ii. When a sample is collected, each end of the collection cylinder should first be covered with a Teflon sheet. Caps should then be placed on the ends of the cylinder and an identifying label attached. Next, the cylinder should be placed in a cooler or ice chest to be chilled. The sample should be placed in a sealed plastic bag before chilling where needed to prevent water damage to the label;
 - iii. The samples should be transported, per arrangements made by the tank owner, to a State Certified Laboratory soon after the completion of sampling. A Chain of Custody form, completed by Environmental Health staff directing the sampling, must accompany the samples to the laboratory. The receiving laboratory should indicate in the designated laboratory section of the Chain of Custody form whether the

samples were received in a chilled state and whether County seals were intact upon arrival, and;

- iv. Samples collected at diesel or gasoline storage sites must be analyzed by an appropriate method for total petroleum hydrocarbons (TPH). TPH (GC/FID) with carbon chain identification is recommended for diesel sites. Total purgeable petroleum hydrocarbons [TPPH (GC/MS)] as gasoline is recommended for gasoline sites. In additional analysis by EPA Method 8260B full scan is required to analyze for volatile organic compounds (VOCs) that include benzene, toluene, ethylbenzene, total xylenes (BTEX), naphthalene, ethanol, Methyl Tertiary Butyl Ether (MTBE) and all other fuel oxygenates. Samples collected at waste oil tank storage sites must be analyzed for TPH with carbon chain identification using EPA Method 8015 or for total recoverable petroleum hydrocarbons using EPA Method 1664, for full scan VOCs including BTEX, MTBE and all other fuel oxygenates, and chlorinated solvents by EPA Method 8260B, and for polycyclic aromatic hydrocarbons using EPA Method 8310 or 8270C (SIM Mode)¹. Detection limits for all reported constituents must meet appropriate data quality objectives.
8. The detection of a reportable unauthorized release, based on field observations and/or the results of the soil and groundwater sample analysis, shall require compliance with the reporting requirements of CCR Section 2652 and the initial abatement and corrective action requirements of Articles 5 and 11 of Title 23, Division 3, Chapter 16, CCR.
 9. The owner of the UST should provide site security to prevent unauthorized public access into excavated areas. This security may include temporary fencing or a twenty-four (24) hour security guard.
 10. The owner of the UST shall have equipment onsite available to control any vapor emissions. The equipment may include bulldozers to backfill excavations and/or tarps to cover contaminated soil.
 11. Documentation required to be forwarded to this Agency after UST removal includes:
 - a. A copy of the certificate of UST destruction,
 - b. Copies, signed by the receiving State permitted facility, of all Uniform Hazardous Waste Manifests used to transport the residual or rinseate liquid, solids, or sludge waste removed from the tanks, and
 - c. Original (wet) copies of the laboratory analytical report, and the white copy of the OCHCA Chain of Custody form, sent with samples to the laboratory, with all required information completed by the laboratory.

Where the above requirements are successfully completed and an unauthorized release requiring further action is not discovered, a completion of a UST closure letter will be issued to the UST owner by Environmental Health. Should an unauthorized release be discovered, Environmental Health's Site Mitigation Section will open a UST cleanup case and, upon satisfactory completion of the required corrective action, a letter of remedial action completion will be issued.

If you have any questions or need additional information, please contact the Environmental Health Hazardous Materials Mitigation Section at (714) 433-6000.

¹ Analytical methods listed above are subject to revision or update by EPA. Suggested test methods may require updating as analytical procedures are promulgated.

SECTION G

APPENDIX "A3"

Operating Permit
and
Location Map(s) of
Existing Police Department Underground Storage Tank



**ORANGE COUNTY CERTIFIED UNIFIED PROGRAM AGENCY
HEALTH CARE AGENCY/ ENVIRONMENTAL HEALTH
PERMIT TO OPERATE
UNDERGROUND STORAGE TANKS**

Program Record ID	Permit Number	Program Code and Description	Permit Valid
PR0024463	PT0030411	7095 - UNDERGROUND STORAGE TANK FACILITY	6/16/2020 To 6/30/2021

Underground Storage Tank Program:
California Health and Safety Code Div. 20, Chap. 6.7 and Title 23 California Code of Regulations Chap. 16.

Tank ID	Capacity	Contents	System Type	Leak Detection
30-000-FA0024551-005	6,000	DIESEL	DOUBLE-WALL	Continuous Interstitial Monitoring

BOE ID#: 44016520

Underground Storage Tank Permit Conditions

The underground storage tanks [UST(s)] located at this facility are permitted to operate provided the following conditions are complied with:

- 1) Facility copy of this permit has an approved monitoring plan, leak response plan, and plot plan attached.
- 2) All unauthorized releases must be reported to this Agency within the time limits and according to the manner specified in Title 23, Sections 2650-55 of the California Code of Regulations (CCR)
- 3) Written records, as required by Section 2712(b), Title 23, CCR, of all monitoring and maintenance performed shall be maintained on-site for a period of at least three (3) years from the date the monitoring was performed. Written records of all monitoring and maintenance performed in the last three (3) years shall be shown to representatives of this Agency upon request during any site inspection.
- 4) The UST(s) must be monitored in accordance with the approved method. This monitoring method is identified above and can be found in Sections 2632 & 2640-48 of Title 23, and Sections 25291 & 25292 of the Health and Safety Code (H&SC).
- 5) The UST(s) owner and operator are subject to all applicable requirements of Chapter 6.7 and Chapter 6.75 of the Health and Safety Code and their regulations.
- 6) Any changes to the information provided in the UST permit application must be reported, within 30 days, to this Agency.

COUNTY OF ORANGE
CERTIFIED UNIFIED PROGRAM AGENCY
1241 EAST DYER ROAD, SUITE 120
SANTA ANA, CA 92705-5611
(714) 433-6000

**PERMITS TO OPERATE are NOT TRANSFERABLE
and may be SUSPENDED or REVOKED for cause.**

PERMIT(s) Valid only for: **CITY OF COSTA MESA**
Tank Owner: **the city of costa mesa**

THIS PERMIT MUST BE RETAINED ON THE PREMISES AND AVAILABLE FOR REVIEW

Regulated Facility: **CITY OF COSTA MESA (POLICE DP)**
99 FAIR DR
COSTA MESA, CA 92626

Facility ID **FA0024551**
CERS ID **10514275**
Issued **06/16/2020**

Permit Mail To: **CITY OF COSTA MESA/ RISK MGT**
77 FAIR DR
COSTA MESA, CA 92626

**Models: G-5, G-6 and DWT-2(B)
6,000 Gallon Tanks**

**P. D. EMERGENCY GENERATOR
TANK #08 --FLEET MANAGEMENT (Actual Capacity 5,929 gal)**

Dipstick	Gallons	Dipstick	Gallons	Dipstick	Gallons	Dipstick	Gallons	Dipstick	Gallons	Dipstick	Gallons	Dipstick	Gallons
40 1/8"	2442	48 1/8"	3156	56 1/8"	3859	64 1/8"	4497	71 1/8"	4999	78 1/8"	5428	85 1/8"	5759
40 1/4"	2459	48 1/4"	3167	56 1/4"	3863	64 1/4"	4506	71 1/4"	5007	78 1/4"	5435	85 1/4"	5758
40 3/8"	2464	48 3/8"	3178	56 3/8"	3874	64 3/8"	4516	71 3/8"	5016	78 3/8"	5442	85 3/8"	5763
40 1/2"	2475	48 1/2"	3189	56 1/2"	3884	64 1/2"	4525	71 1/2"	5024	78 1/2"	5449	85 1/2"	5767
40 5/8"	2486	48 5/8"	3201	56 5/8"	3895	64 5/8"	4535	71 5/8"	5032	78 5/8"	5455	85 5/8"	5772
40 3/4"	2497	48 3/4"	3212	56 3/4"	3905	64 3/4"	4544	71 3/4"	5040	78 3/4"	5462	85 3/4"	5777
40 7/8"	2508	48 7/8"	3223	56 7/8"	3916	64 7/8"	4554	71 7/8"	5049	78 7/8"	5468	85 7/8"	5781
41"	2519	49"	3234	57"	3926	65"	4563	72"	5057	79"	5475	86"	5786
41 1/8"	2530	49 1/8"	3245	57 1/8"	3936	65 1/8"	4573	72 1/8"	5065	79 1/8"	5481	86 1/8"	5790
41 1/4"	2541	49 1/4"	3256	57 1/4"	3947	65 1/4"	4582	72 1/4"	5073	79 1/4"	5488	86 1/4"	5794
41 3/8"	2552	49 3/8"	3267	57 3/8"	3957	65 3/8"	4591	72 3/8"	5081	79 3/8"	5494	86 3/8"	5799
41 1/2"	2563	49 1/2"	3278	57 1/2"	3968	65 1/2"	4601	72 1/2"	5089	79 1/2"	5501	86 1/2"	5803
41 5/8"	2574	49 5/8"	3289	57 5/8"	3978	65 5/8"	4610	72 5/8"	5098	79 5/8"	5507	86 5/8"	5807
41 3/4"	2585	49 3/4"	3300	57 3/4"	3988	65 3/4"	4619	72 3/4"	5106	79 3/4"	5513	86 3/4"	5812
41 7/8"	2596	49 7/8"	3312	57 7/8"	3999	65 7/8"	4629	72 7/8"	5114	79 7/8"	5520	86 7/8"	5816
42"	2607	50"	3323	58"	4009	66"	4638	73"	5122	80"	5526	87"	5820
42 1/8"	2618	50 1/8"	3334	58 1/8"	4020	66 1/8"	4647	73 1/8"	5130	80 1/8"	5532	87 1/8"	5824
42 1/4"	2629	50 1/4"	3345	58 1/4"	4030	66 1/4"	4656	73 1/4"	5138	80 1/4"	5538	87 1/4"	5828
42 3/8"	2640	50 3/8"	3356	58 3/8"	4040	66 3/8"	4665	73 3/8"	5145	80 3/8"	5544	87 3/8"	5832
42 1/2"	2651	50 1/2"	3367	58 1/2"	4050	66 1/2"	4675	73 1/2"	5153	80 1/2"	5551	87 1/2"	5836
42 5/8"	2662	50 5/8"	3378	58 5/8"	4061	66 5/8"	4684	73 5/8"	5161	80 5/8"	5557	87 5/8"	5840
42 3/4"	2673	50 3/4"	3389	58 3/4"	4071	66 3/4"	4693	73 3/4"	5169	80 3/4"	5563	87 3/4"	5843
42 7/8"	2684	50 7/8"	3400	58 7/8"	4081	66 7/8"	4702	73 7/8"	5177	80 7/8"	5569	87 7/8"	5847
43"	2695	51"	3411	59"	4091	67"	4711	74"	5185	81"	5575	88"	5851
43 1/8"	2707	51 1/8"	3422	59 1/8"	4102	67 1/8"	4720	74 1/8"	5192	81 1/8"	5581	88 1/8"	5854
43 1/4"	2718	51 1/4"	3433	59 1/4"	4112	67 1/4"	4729	74 1/4"	5200	81 1/4"	5587	88 1/4"	5858
43 3/8"	2729	51 3/8"	3444	59 3/8"	4122	67 3/8"	4738	74 3/8"	5208	81 3/8"	5593	88 3/8"	5862
43 1/2"	2740	51 1/2"	3455	59 1/2"	4132	67 1/2"	4747	74 1/2"	5216	81 1/2"	5599	88 1/2"	5865
43 5/8"	2751	51 5/8"	3466	59 5/8"	4142	67 5/8"	4756	74 5/8"	5223	81 5/8"	5604	88 5/8"	5868
43 3/4"	2762	51 3/4"	3476	59 3/4"	4153	67 3/4"	4765	74 3/4"	5231	81 3/4"	5610	88 3/4"	5872
43 7/8"	2773	51 7/8"	3487	59 7/8"	4163	67 7/8"	4774	74 7/8"	5239	81 7/8"	5616	88 7/8"	5875
44"	2785	52"	3498	60"	4173	68"	4783	75"	5246	82"	5622	89"	5878
44 1/8"	2796	52 1/8"	3509	60 1/8"	4183	68 1/8"	4792	75 1/8"	5254	82 1/8"	5627	89 1/8"	5881
44 1/4"	2807	52 1/4"	3520	60 1/4"	4193	68 1/4"	4801	75 1/4"	5261	82 1/4"	5633	89 1/4"	5884
44 3/8"	2818	52 3/8"	3531	60 3/8"	4203	68 3/8"	4810	75 3/8"	5269	82 3/8"	5639	89 3/8"	5887
44 1/2"	2829	52 1/2"	3542	60 1/2"	4213	68 1/2"	4819	75 1/2"	5276	82 1/2"	5644	89 1/2"	5890
44 5/8"	2841	52 5/8"	3553	60 5/8"	4223	68 5/8"	4827	75 5/8"	5284	82 5/8"	5650	89 5/8"	5893
44 3/4"	2852	52 3/4"	3564	60 3/4"	4233	68 3/4"	4836	75 3/4"	5291	82 3/4"	5655	89 3/4"	5896
44 7/8"	2863	52 7/8"	3574	60 7/8"	4243	68 7/8"	4845	75 7/8"	5299	82 7/8"	5661	89 7/8"	5899
45"	2874	53"	3585	61"	4253	69"	4854	76"	5306	83"	5666	90"	5901
45 1/8"	2885	53 1/8"	3596	61 1/8"	4263	69 1/8"	4862	76 1/8"	5313	83 1/8"	5672	90 1/8"	5904
45 1/4"	2897	53 1/4"	3607	61 1/4"	4273	69 1/4"	4871	76 1/4"	5321	83 1/4"	5677	90 1/4"	5907
45 3/8"	2908	53 3/8"	3618	61 3/8"	4283	69 3/8"	4880	76 3/8"	5328	83 3/8"	5682	90 3/8"	5909
45 1/2"	2919	53 1/2"	3629	61 1/2"	4293	69 1/2"	4889	76 1/2"	5335	83 1/2"	5688	90 1/2"	5911
45 5/8"	2931	53 5/8"	3639	61 5/8"	4303	69 5/8"	4897	76 5/8"	5343	83 5/8"	5693	90 5/8"	5913
45 3/4"	2942	53 3/4"	3650	61 3/4"	4313	69 3/4"	4906	76 3/4"	5350	83 3/4"	5698	90 3/4"	5916
45 7/8"	2953	53 7/8"	3661	61 7/8"	4322	69 7/8"	4914	76 7/8"	5357	83 7/8"	5703	90 7/8"	5918
46"	2965	54"	3672	62"	4332	70"	4923	77"	5364	84"	5709	91"	5919
46 1/8"	2976	54 1/8"	3682	62 1/8"	4342	70 1/8"	4931	77 1/8"	5371	84 1/8"	5714	91 1/8"	5921
46 1/4"	2987	54 1/4"	3693	62 1/4"	4352	70 1/4"	4940	77 1/4"	5379	84 1/4"	5719	91 1/4"	5923
46 3/8"	2999	54 3/8"	3704	62 3/8"	4362	70 3/8"	4949	77 3/8"	5386	84 3/8"	5724	91 3/8"	5924
46 1/2"	3010	54 1/2"	3715	62 1/2"	4371	70 1/2"	4957	77 1/2"	5393	84 1/2"	5729	91 1/2"	5926
46 5/8"	3021	54 5/8"	3725	62 5/8"	4381	70 5/8"	4965	77 5/8"	5400	84 5/8"	5734	91 5/8"	5927
46 3/4"	3033	54 3/4"	3736	62 3/4"	4391	70 3/4"	4974	77 3/4"	5407	84 3/4"	5739	91 3/4"	5928
46 7/8"	3044	54 7/8"	3747	62 7/8"	4401	70 7/8"	4982	77 7/8"	5414	84 7/8"	5744	91 7/8"	5929
47"	3055	55"	3757	63"	4410	71"	4991	78"	5421	85"	5748	92"	5929
47 1/8"	3066	55 1/8"	3768	63 1/8"	4420								
47 1/4"	3078	55 1/4"	3778	63 1/4"	4430								
47 3/8"	3089	55 3/8"	3789	63 3/8"	4439								
47 1/2"	3100	55 1/2"	3800	63 1/2"	4449								
47 5/8"	3111	55 5/8"	3810	63 5/8"	4459								
47 3/4"	3122	55 3/4"	3821	63 3/4"	4468								
47 7/8"	3134	55 7/8"	3831	63 7/8"	4478								
48"	3145	56"	3842	64"	4487								

**P. D. EMERGENCY GENERATOR
-- FLEET MANAGEMENT**



O/C Tanks Corporation
One Levis Square, Box 10025
Toledo, Ohio 43699-0025

Fiberglas® Tanks for Fuel Storage

Calibration Chart*

How to properly gauge your tank:...

Underground storage tanks require periodic measurement to determine current inventory level. Using the proper methods when gauging your tank's contents will insure the most accurate reading and insure that you do not damage your tank. The following procedure should be followed whenever you use a gauge stick to determine the amount of product that is in your tank:

1. Use a wood dipstick with a rubber or nylon tip. Metallic dipsticks are not recommended. This will insure that frequent tank gaugings or an accidental dropping of the gauge stick into the tank will not damage the tank bottom.
2. Always gauge your tank at the fill port. A tank bottom protector plate has been installed under this port to help protect the tank.
3. Slowly lower your gauge stick into the fill port until it touches the tank bottom. Never free drop the gauge stick. This can result in inaccurate measurements due to product splashing. Free dropping can also result in gauge stick damage and tank damage.
4. Remove your dipstick slowly and read the product level directly from the gauge stick.

Dipstick	Gallons	Dipstick	Gallons	Dipstick	Gallons	Dipstick	Gallons	Dipstick	Gallons
1/8"	0	8 1/8"	226	16 1/4"	691	24 1/8"	1155	32 1/8"	1767
1/4"	1	8 1/4"	231	16 1/2"	698	24 1/4"	1164	32 1/4"	1777
3/8"	2	8 3/8"	236	16 3/4"	706	24 3/8"	1173	32 3/8"	1787
1/2"	3	8 1/2"	242	16 7/8"	713	24 1/2"	1182	32 1/2"	1797
5/8"	5	8 5/8"	247	17"	721	24 5/8"	1191	32 5/8"	1807
3/4"	6	8 3/4"	252	17 1/8"	729	24 3/4"	1200	32 3/4"	1818
7/8"	8	8 7/8"	258	17 1/4"	737	24 7/8"	1209	32 7/8"	1828
1"	10	9"	263	17 1/2"	745	25"	1218	33"	1838
1 1/8"	12	9 1/8"	268	17 3/4"	752	25 1/8"	1227	33 1/8"	1848
1 1/4"	14	9 1/4"	274	17 7/8"	759	25 1/4"	1236	33 1/4"	1858
1 3/8"	16	9 3/8"	279	17 7/8"	766	25 3/8"	1245	33 3/8"	1869
1 1/2"	18	9 1/2"	285	17 7/8"	774	25 1/2"	1253	33 1/2"	1879
1 5/8"	20	9 5/8"	291	17 3/4"	781	25 5/8"	1261	33 5/8"	1889
1 3/4"	23	9 3/4"	296	17 3/4"	789	25 3/4"	1270	33 3/4"	1900
1 7/8"	25	9 7/8"	302	17 3/4"	797	25 7/8"	1278	33 7/8"	1910
2"	28	10"	308	18"	805	26"	1287	34"	1920
2 1/8"	31	10 1/8"	313	18 1/8"	812	26 1/8"	1295	34 1/8"	1931
2 1/4"	33	10 1/4"	319	18 1/4"	820	26 1/4"	1304	34 1/4"	1941
2 3/8"	36	10 3/8"	325	18 1/4"	827	26 3/8"	1312	34 3/8"	1951
2 1/2"	39	10 1/2"	331	18 1/2"	835	26 1/2"	1321	34 1/2"	1962
2 5/8"	42	10 5/8"	337	18 1/2"	842	26 5/8"	1329	34 5/8"	1972
2 3/4"	45	10 3/4"	343	18 3/4"	850	26 3/4"	1337	34 3/4"	1982
2 7/8"	48	10 7/8"	349	18 3/4"	857	26 7/8"	1346	34 7/8"	1993
3"	51	11"	355	19"	865	27"	1354	35"	2003
3 1/8"	54	11 1/8"	361	19 1/8"	872	27 1/8"	1363	35 1/8"	2014
3 1/4"	58	11 1/4"	367	19 1/4"	880	27 1/4"	1371	35 1/4"	2024
3 3/8"	61	11 3/8"	373	19 3/8"	887	27 3/8"	1380	35 3/8"	2035
3 1/2"	64	11 1/2"	379	19 1/2"	895	27 1/2"	1388	35 1/2"	2045
3 5/8"	68	11 5/8"	385	19 5/8"	902	27 5/8"	1397	35 5/8"	2056
3 3/4"	71	11 3/4"	391	19 3/4"	910	27 3/4"	1405	35 3/4"	2066
3 7/8"	75	11 7/8"	397	19 7/8"	917	27 7/8"	1414	35 7/8"	2077
4"	79	12"	403	20"	925	28"	1422	36"	2087
4 1/8"	82	12 1/8"	410	20 1/8"	932	28 1/8"	1431	36 1/8"	2098
4 1/4"	86	12 1/4"	416	20 1/4"	939	28 1/4"	1440	36 1/4"	2108
4 3/8"	90	12 3/8"	422	20 3/8"	947	28 3/8"	1448	36 3/8"	2119
4 1/2"	94	12 1/2"	429	20 1/2"	954	28 1/2"	1457	36 1/2"	2130
4 5/8"	98	12 5/8"	435	20 5/8"	962	28 5/8"	1465	36 5/8"	2140
4 3/4"	102	12 3/4"	442	20 3/4"	969	28 3/4"	1474	36 3/4"	2151
4 7/8"	106	12 7/8"	448	20 7/8"	977	28 7/8"	1482	36 7/8"	2162
5"	110	13"	454	21"	984	29"	1491	37"	2172
5 1/8"	114	13 1/8"	461	21 1/8"	992	29 1/8"	1500	37 1/8"	2183
5 1/4"	118	13 1/4"	468	21 1/4"	999	29 1/4"	1508	37 1/4"	2194
5 3/8"	122	13 3/8"	474	21 3/8"	1007	29 3/8"	1517	37 3/8"	2204
5 1/2"	126	13 1/2"	481	21 1/2"	1014	29 1/2"	1525	37 1/2"	2215
5 5/8"	131	13 5/8"	488	21 5/8"	1022	29 5/8"	1534	37 5/8"	2226
5 3/4"	135	13 3/4"	495	21 3/4"	1029	29 3/4"	1542	37 3/4"	2236
5 7/8"	139	13 7/8"	502	21 7/8"	1037	29 7/8"	1551	37 7/8"	2247
6"	144	14"	509	22"	1044	30"	1560	38"	2258
6 1/8"	148	14 1/8"	516	22 1/8"	1052	30 1/8"	1568	38 1/8"	2269
6 1/4"	153	14 1/4"	523	22 1/4"	1059	30 1/4"	1577	38 1/4"	2279
6 3/8"	157	14 3/8"	530	22 3/8"	1067	30 3/8"	1585	38 3/8"	2290
6 1/2"	162	14 1/2"	537	22 1/2"	1074	30 1/2"	1594	38 1/2"	2301
6 5/8"	167	14 5/8"	544	22 5/8"	1082	30 5/8"	1602	38 5/8"	2312
6 3/4"	171	14 3/4"	551	22 3/4"	1089	30 3/4"	1611	38 3/4"	2322
6 7/8"	176	14 7/8"	558	22 7/8"	1097	30 7/8"	1619	38 7/8"	2333
7"	181	15"	565	23"	1104	31"	1628	39"	2344
7 1/8"	186	15 1/8"	572	23 1/8"	1112	31 1/8"	1636	39 1/8"	2355
7 1/4"	191	15 1/4"	580	23 1/4"	1119	31 1/4"	1645	39 1/4"	2366
7 3/8"	196	15 3/8"	587	23 3/8"	1127	31 3/8"	1653	39 3/8"	2377
7 1/2"	201	15 1/2"	594	23 1/2"	1134	31 1/2"	1662	39 1/2"	2387
7 5/8"	206	15 5/8"	601	23 5/8"	1142	31 5/8"	1670	39 5/8"	2398
7 3/4"	211	15 3/4"	609	23 3/4"	1149	31 3/4"	1679	39 3/4"	2409
7 7/8"	216	15 7/8"	616	23 7/8"	1157	31 7/8"	1687	39 7/8"	2420
8"	221	16"	623	24"	1164	32"	1696	40"	2431

For Model DWT-2P double-wall tanks only, the annular space capacity for this tank is 340 gallons.

P.D. EMERGENCY GENERATOR
-FLEET MANAGEMENT



O/C TANKS

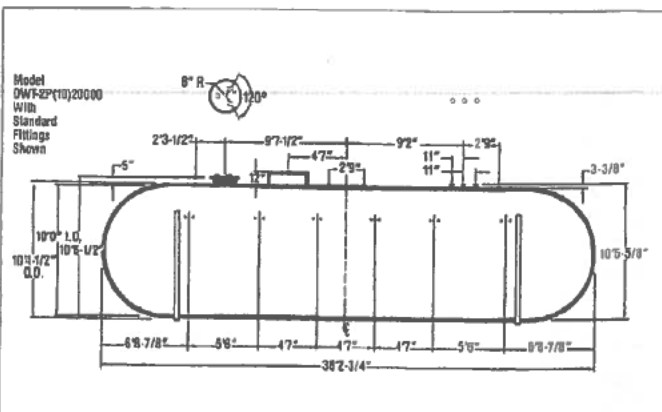
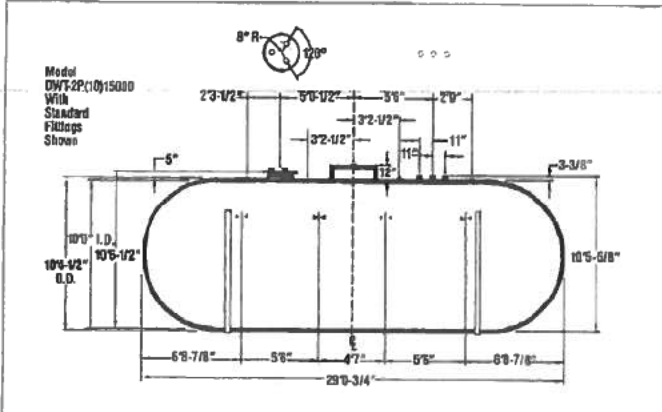
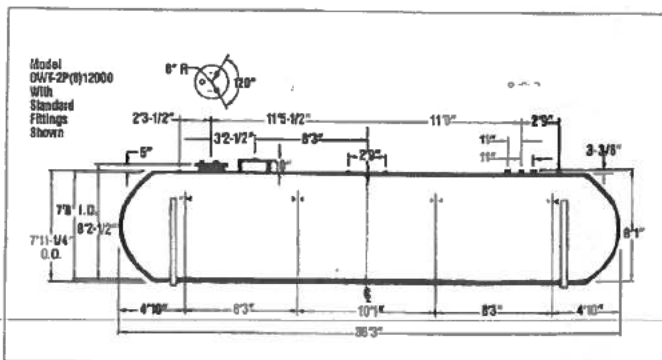
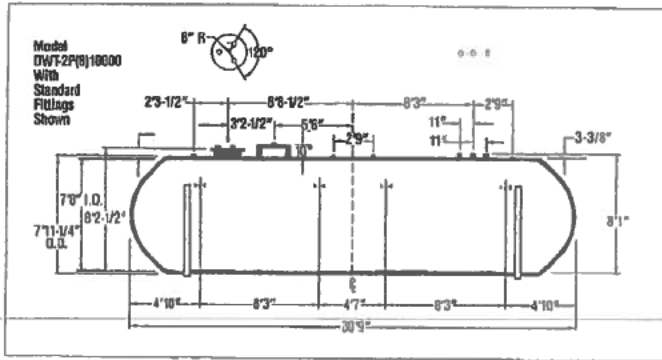
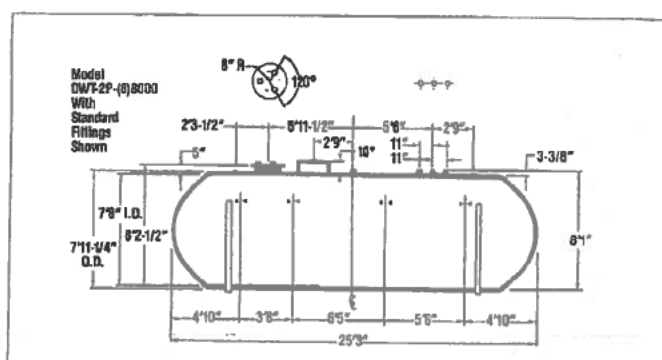
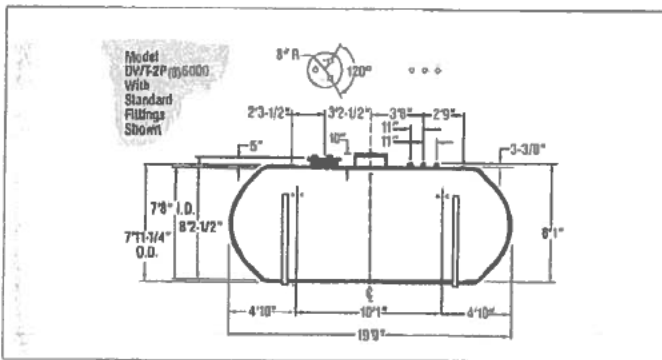
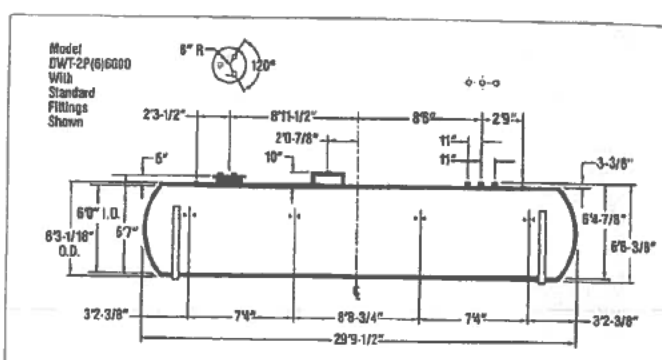
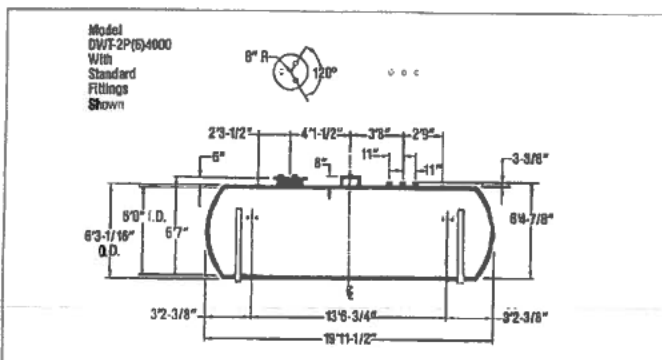
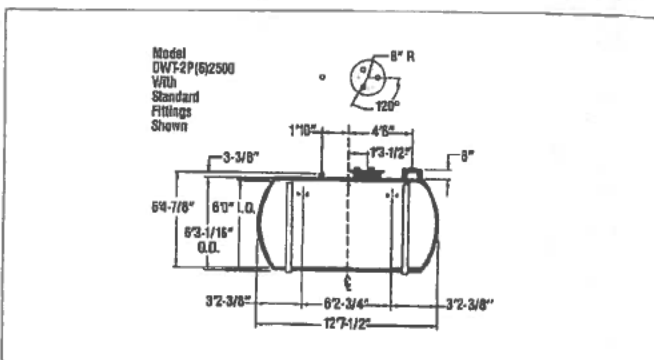
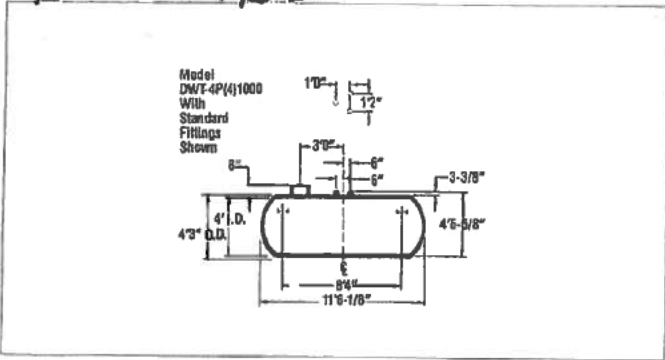

O/C TANKS

Standard Double-Wall Tanks

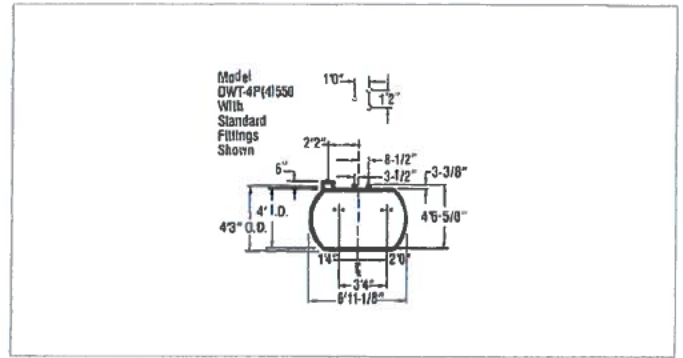

Standard Double-Wall Tank Specifications

Tank Model	Nominal Capacity (Gallons)	Actual Capacity (Gallons)	Number of 22" Manways	Number of 4" NPT Primary Tank Fittings (#/Tank)	Nominal Weight (lbs.)	Approx. Cavity Volume (Gallons)	Overall Length	Tank Diameter	Number of 4" Tank Monitoring* Fittings	Cavity Spacing Between Inner and Outer Tank
DWT-4P(4)	550	550	0	3	650	75	6' 11-1/8"	4'	1	1-1/8"
DWT-4P(4)	1,000	1,000	0	3	950	140	11' 6-1/8"	4'	1	1-1/8"
DWT-2P(6)	2,500	2,500	1	4	1,800	180	12' 7-1/2"	6'	1	1-1/8"
DWT-2P(6)	4,000	4,000	1	6	2,500	270	19' 11-1/2"	6'	3	1-1/8"
**DWT-2P(6)	6,000	6,000	1	6	3,400	405	29' 9-1/2"	6'	3	1-1/8"
DWT-2P(8)	6,000	6,000	1	6	3,400	340	19' 9"	8'	3	1-1/8"
DWT-2P(8)	8,000	8,000	1	6	4,200	425	25' 3"	8'	3	1-1/8"
DWT-2P(8)	10,000	10,000	1	6	5,000	550	30' 9"	8'	3	1-1/8"
DWT-2P(8)	12,000	12,000	1	6	6,000	585	36' 3"	8'	3	1-1/8"
DWT-2P(10)	15,000	15,000	1	6	8,500	1,020	29' 1"	10'	3	1-3/4"
DWT-2P(10)	20,000	20,000	1	6	11,000	1,364	38' 3"	10'	3	1-3/4"

*Includes fitting in Fiberglass reservoir

**The 6,000 gallon DWT-2P(6) is standard at Mt. Union, PA plant only. At all other plants, DWT-2P(6) 6000 model is made-to-order.

Standard Tank Notes

- Standard pipe fittings to the primary tank are 4" NPT half couplings. All tanks 2,500 gallon capacity and larger include one manway with three fittings to the primary tank located in the manway cover. All other primary tank fittings are mounted on the tank. Additional manways and tank fittings are available on made-to-order tanks.
- Tank bottom deflector plates are standard under every manway and fitting.
- Bumper pads are standard on all tanks 6' diameter and larger. The pads provide added protection to the tank prior to installation.
- All Model "P" tanks include a Fiberglass reservoir, used for leak monitoring, integrally constructed to the tank top. The reservoir includes one 4" NPT half coupling fitting mounted on the top of the reservoir allowing access to the cavity between the inner and outer tank walls.
- In addition to the monitoring fitting located in the Fiberglass reservoir, tanks 1,000 gallon capacity and larger include additional monitoring fittings (4" NPT) located at the tank top. See the tank specifications for the number of monitoring fittings for each tank size.
- Anchoring strap locations are indicated by arrows on the side of the tank.
- Monitoring capabilities—the following restrictions apply for the various types of double-wall tank monitors:
 - Hydrostatic Tank Monitor—tank burial depth must not exceed 7' from tank top to finish grade. The monitoring cavity must be vented to the atmosphere. The optional reservoir sensor, supplied by O/C Tanks, is designed to automatically vent the monitoring cavity.
 - Liquid sensors—when normally "dry" cavity monitors (which detect the presence of a liquid) are used, the cavity between the inner and outer tank may be either vented to the atmosphere or sealed.
 - Vacuum monitoring—when vacuum monitoring is used, the maximum vacuum is 3" mercury (1.5 psi maximum).
 - Positive air pressure monitoring—when positive air pressure monitoring is used, the maximum air pressure is 3 psi.
 - Gasoline vapor sensors—when gasoline vapor sensors are used, the cavity between the inner and outer tank may be either vented to the atmosphere or sealed.

O/C Tanks Warranty And Installation Information

Accessories Warranty

All double-wall tank accessories and monitoring equipment are warranted to be free from material defects in workmanship and materials for a period of one (1) year following date of original delivery by O/C Tanks.

Our liability under this warranty shall be limited to, at our option, (i) repair of the defective unit, (ii) delivery of a replacement unit to the point of original delivery, or (iii) refund of the original purchase price, and we shall not be liable for any labor, other installation costs, indirect or consequential damages or other damages in connection with such tanks. THE FOREGOING CONSTITUTES OUR EXCLUSIVE OBLIGATION AND WE MAKE NO EXPRESS OR IMPLIED WARRANTIES, OR ANY WARRANTY OF MERCHANTABILITY OR FITNESS FOR ANY PARTICULAR PURPOSE WHATSOEVER, EXCEPT AS STATED ABOVE.

Failure to install the tank accessories or monitoring equipment in accordance with the O/C Tanks installation instructions will void the warranty.

Fiberglas® Tanks Intended Use

Fiberglas® petroleum storage tanks are designed for the storage of gasoline, gasohol (10% ethanol and 90% gasoline mixture), 9.5% Oxinol-50* (4.75% methanol and 4.75% GTBA) and 90.5% gasoline mixture, jet fuel, kerosene, diesel fuel, oxygenated fuels, (up to 20% MTBE) or potable water at ambient underground temperatures. Fuel oil may be stored at temperatures not to exceed 150° F.

CAUTION: Fiberglas tanks are not recommended for #6 fuel oil storage; typical delivery temperatures of #6 fuel oil exceeds 150°F.

The storage of other materials may affect the life of the tank. Before storing materials other than those listed above contact the Product Manager, O/C Tanks Corporation, Toledo, Ohio.

Warranty

Standard Underground Petroleum Storage Tank

We warrant that our underground tanks and piping sumps,* if installed underground with proper backfill and otherwise installed in accordance with our instructions:

- I. Will meet our published specifications and will be free from material defects in materials and workmanship for a period of one (1) year following date of original delivery by us;
- II. Will not fail for a period of thirty (30) years from date of original purchase due to external corrosion; and
- III. Will not fail for a period of thirty (30) years from date of original purchase due to internal corrosion provided the tank is used solely with or without tank water bottoms for the following products:
 - A. Petroleum products including gasoline, jet fuel, av-gas, motor oil (new or used), kerosene, diesel fuel or used for fuel oil at temperatures not to exceed 150°F.
 - B. Alcohol-gasoline blend motor fuels.
 1. Ethanol blends
 - Gasohol (90% gasoline and 10% ethyl alcohol)
 2. Methanol blends
 - Oxinol-50* waiver (90.5% gasoline and 9.5% Oxinol-50* composed of a mixture of 4.75% methanol and 4.75% GTBA).
 - DuPont EPA waiver (gasoline with 5% methanol and a minimum of 2.5% cosolvent. The blend may contain a maximum concentration of up to 3.7 weight percent oxygen in the final fuel).
 - C. Oxygenated motor fuels
 - Gasoline with up to 20% (by volume) of methyl tertiary butyl ether (MTBE)
 - D. Potable water at ambient temperatures.
- IV. Will not leak for a period of thirty (30) years from date of original purchase due to structural failure, which shall be defined as breaking or collapse, provided the installation is in the United States and is performed and validated by a contractor trained by O/C Tanks, and is used as stated above. If the tank is exhumed and moved, it must be inspected, repaired (as necessary), and recertified by O/C Tanks in order to continue the structural warranty for the balance of 30 years.

Our liability under this warranty shall be limited to, at our option, (i) repair of the defective tank, (ii) delivery of a replacement tank to the point of original delivery, or (iii) refund of the original purchase price, and we shall not be liable for any labor, other installation costs, indirect or consequential damages or other damages in connection with such tanks. THE FOREGOING CONSTITUTES OUR EXCLUSIVE OBLIGATION AND WE MAKE NO EXPRESS OR IMPLIED WARRANTIES, OR ANY WARRANTY OF MERCHANTABILITY OR FITNESS FOR ANY PARTICULAR PURPOSE WHATSOEVER, EXCEPT AS STATED ABOVE.

*Fiberglas components only



O/C TANKS CORPORATION
A Subsidiary of Owens-Corning Fiberglas
One Lewis Square, PO Box 10025
Toledo, Ohio 43699-0025



To Whom It May Concern

RE: Fuel Storage Capability

Owens Corning manufactured and sold underground storage tanks between 1965 and 1994. The Company's fiberglass tank division was sold December 31, 1994. Owens Corning has not manufactured or sold tanks since that time.

With limited exceptions, Owens Corning fiberglass tanks were not warranted, tested for, or intended to store fuel with more than a 10% ethanol blend.

Single-Wall Tanks (SWT): No Owens Corning SWT was ever warranted or intended to store fuel with more than a 10% ethanol blend.

Double-Wall Tanks (DWT): *Prior to July 1, 1990.* With the exception of a small number of specially manufactured tanks, DWTs sold before July 1, 1990 were not warranted or intended to store fuel with more than a 10% ethanol blend.

After July 1, 1990. Owens Corning DWTs that were manufactured and sold between July 1, 1990 and December 31, 1994 were warranted for the storage of fuel with no limitation on ethanol content.

For additional details, please refer to the attached letter from Owens Corning to customers from April 1995. Please also note that in addition to these compatibility limitations, in 2006 Owens Corning completed reorganization under Chapter 11 of the Bankruptcy Code. Under the confirmed plan of reorganization, all past and future claims against Owens Corning for alleged breach of warranty were discharged in bankruptcy.

Sincerely,

A handwritten signature in black ink, appearing to read "Brian McPeak".

Brian McPeak
Vice President, External Affairs

Vanguard Way

Grass

Tank #4
Exempt

6,000 Gallon
Gasoline UST

Grass

Sidewalk

Building

LEGEND

Scale: 1" = 10'
0 10'



Ocean Blue Engineers, Inc.

PARTIAL PROPERTY PLOT PLAN
City of Costa Mesa Police Department
Showing the 6,000 Gallon
Diesel UST
99 Fair Drive
Costa Mesa, CA 92626

Project No.
1426.2020.0-29

Drawing No.
5

THE CITY OF COSTA MESA FUEL TANK LIST

FACILITY	TANK ID #	ADDRESS	POSITION	CAPACITY IN GALLONS	CONTENTS	MONITORING SYSTEM
CITY CORPORATION YARD	1	2300 PLACENTIA AVE	UNDERGROUND	2,500	DIESEL	VEEDER ROOT TLS 350
CITY CORPORATION YARD	2	2300 PLACENTIA AVE	UNDERGROUND	8,000	DIESEL	VEEDER ROOT TLS 350
CITY CORPORATION YARD	3	2300 PLACENTIA AVE	UNDERGROUND	8,000	GASOLINE	VEEDER ROOT TLS 350
CITY CORPORATION YARD	6	2300 PLACENTIA AVE	UNDERGROUND	10,000	GASOLINE	VEEDER ROOT TLS 350
CITY CORPORATION YARD		2300 PLACENTIA AVE	ABOVE GROUND	1,500/ 500	OIL/WASTE OIL	VEEDER ROOT
POLICE DEPARTMENT	7	99 FAIR DRIVE	ABOVE GROUND	10,000	GASOLINE	VEEDER ROOT TLS 350
POLICE DEPARTMENT	8	99 FAIR DRIVE	ABOVE GROUND	4,000	DIESEL	
POLICE DEPARTMENT	9	99 FAIR DRIVE	UNDERGROUND	6,000	DIESEL	VEEDER ROOT TLS 350
FIRE STATION 2	12	800 BAKER STREET	UNDERGROUND	1,000	DIESEL	TLS 300C
FIRE STATION 1	13	2803 Royal Palm	ABOVE GROUND	2,000	DIESEL	VEEDER ROOT TLS 350R
FIRE STATION 5	14	2450 VANGUARD WAY	ABOVE GROUND	1,000	DIESEL	VEEDER ROOT
FIRE STATION 6	15	3350 SAKIOKA DRIVE	UNDERGROUND	1,000	DIESEL	VEEDER ROOT
COMMUNICATIONS	16	99 FAIR DRIVE	ABOVE GROUND	1,000	DIESEL	NONE
CITY HALL GENERATOR	17	77 FAIR DRIVE	ABOVE GROUND	2,000	DIESEL	NONE

CITY OF COSTA MESA MASTER TANK LISTING

July 23, 1997

PUBLIC SERVICES/FACILITIES AND EQUIPMENT

RECEIVED
JUL 28 1997
COSTA MESA

NO. TANKS	I.D. NO.	CAPACITY (IN GALLONS)		MATERIAL STORED	LOCATION	ADDRESS	DATE INSTALLED	OCHCA PERMIT NO.	PERMIT ISSUANCE	PERMIT EXPIRATION
		RATED	ACTUAL							
1	CY-1	10,000	9,728	Gasoline	Corporation Yard	2310 Placentia	Nov-76	6399-1	09/02/92	09/01/97
2	CY-2	8,000	7,829	DIESEL	Corporation Yard	2310 Placentia	Mar-86	6399-1	09/02/92	09/01/97
3	CY-3	8,000	7,829	Gasoline	Corporation Yard	2310 Placentia	Mar-86	6399-1	09/02/92	09/01/97
4	CY-4	2,500	2,385	Diesel Fuel	Corporation Yard	2310 Placentia	Mar-86	6399-1	09/02/92	09/01/97
5	CY-5	250	245	Waste Oil	Corporation Yard	2310 Placentia	Dec-87	6399-1	09/02/92	09/01/97
6	CY-6	250	495	Oil (New)	Corporation Yard	2310 Placentia	Aug-85	6399-1	09/02/92	09/01/97
7	CY-7	500	495	Transmission Oil	Corporation Yard	2310 Placentia	Aug-85	6399-1	09/02/92	09/01/97
8	CY-8	500	495	Solvent	Corporation Yard	2310 Placentia	Aug-85	6399-1	09/02/92	09/01/97
9	CY-9	1,150	1,150	Propane	Corporation Yard	2310 Placentia	1970	N/A	N/A	N/A
10	F.S. 1	1,000	971	Gasoline	Fire Station #1	2803 Royal Palm	Dec-87	6415-2	08/14/96	08/13/01
11	F.S. 1	1,000	971	Diesel Fuel	Fire Station #1	2803 Royal Palm	Dec-87	6415-2	08/14/96	08/13/01
12	F.S. 2	1,000	971	Diesel Fuel	Fire Station #2	800 Baker	Dec-87	6691-2	08/14/96	08/13/01
13	F.S. 3	1,000	971	Diesel Fuel	Fire Station #3	1865 Park	Sep-89	6395-2	02/21/93	02/20/98
14	F.S. 5	1,000	971	Diesel Fuel	Fire Station #5	2450 Vanguard	Mar-89	10051-1	03/09/96	03/08/01
15	F.S. 6	1,000	971	Diesel Fuel	Fire Station #6	2350 Sakioka	Jul-93	12521-1	09/21/93	09/20/98
16	P.D. 1	10,000	9,728	Gasoline	Police Department	99 Fair Drive	Dec-87	6698-2	08/14/96	08/13/01
17	P.D. 2	6,000	5,929	Diesel Fuel - Generator	Police Department	99 Fair Drive	Sep-90	6698-2	08/14/96	08/13/01
18	AC	10,000	10,018	Jet A Fuel	Helipad	99 Fair Drive	Aug-84	6698-2	08/14/96	08/13/01

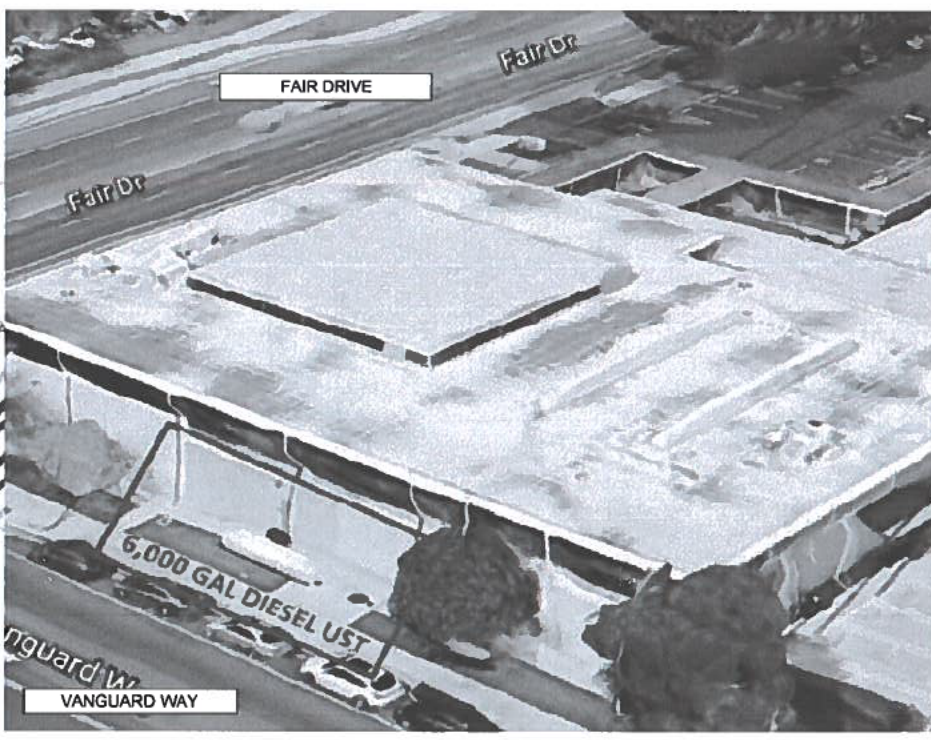

SECTION G

APPENDIX "A4"

EXISTING:

**BUILDING CIVIL PLANS
C2.0**

**STRUCTURAL PLANS
S2.1
S2.2
S3.2**

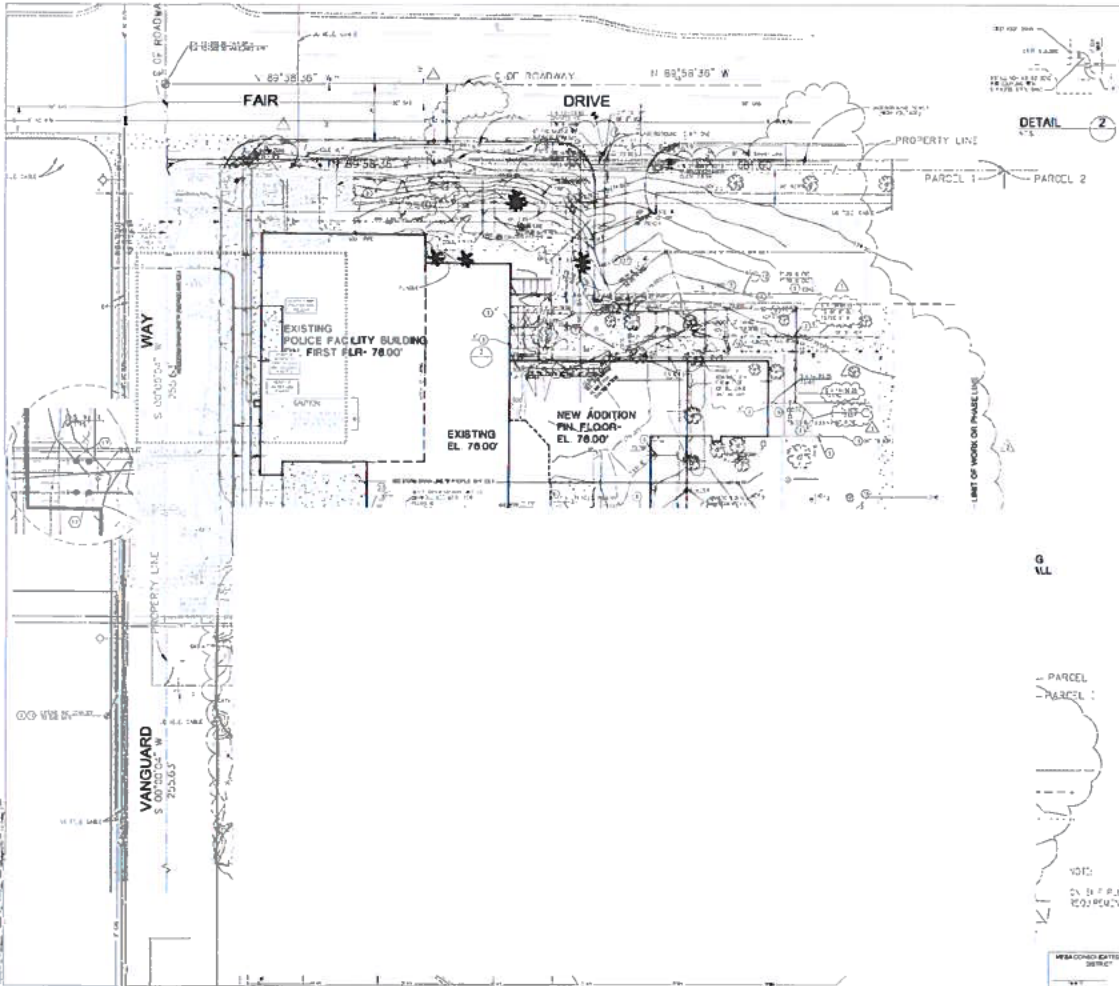

CONSTRUCTION NOTES

1. EXISTING UTILITIES TO REMAIN AS SHOWN ON THESE PLANS UNLESS INDICATED OTHERWISE.
2. ALL NEW UTILITIES TO BE INSTALLED AS SHOWN ON THESE PLANS UNLESS INDICATED OTHERWISE.
3. ALL UTILITIES TO BE INSTALLED AT A MINIMUM 18" FROM THE EXISTING BUILDING FOUNDATION UNLESS OTHERWISE INDICATED.
4. ALL UTILITIES TO BE INSTALLED AT A MINIMUM 18" FROM THE EXISTING BUILDING FOUNDATION UNLESS OTHERWISE INDICATED.
5. ALL UTILITIES TO BE INSTALLED AT A MINIMUM 18" FROM THE EXISTING BUILDING FOUNDATION UNLESS OTHERWISE INDICATED.
6. ALL UTILITIES TO BE INSTALLED AT A MINIMUM 18" FROM THE EXISTING BUILDING FOUNDATION UNLESS OTHERWISE INDICATED.
7. ALL UTILITIES TO BE INSTALLED AT A MINIMUM 18" FROM THE EXISTING BUILDING FOUNDATION UNLESS OTHERWISE INDICATED.
8. ALL UTILITIES TO BE INSTALLED AT A MINIMUM 18" FROM THE EXISTING BUILDING FOUNDATION UNLESS OTHERWISE INDICATED.
9. ALL UTILITIES TO BE INSTALLED AT A MINIMUM 18" FROM THE EXISTING BUILDING FOUNDATION UNLESS OTHERWISE INDICATED.
10. ALL UTILITIES TO BE INSTALLED AT A MINIMUM 18" FROM THE EXISTING BUILDING FOUNDATION UNLESS OTHERWISE INDICATED.
11. ALL UTILITIES TO BE INSTALLED AT A MINIMUM 18" FROM THE EXISTING BUILDING FOUNDATION UNLESS OTHERWISE INDICATED.
12. ALL UTILITIES TO BE INSTALLED AT A MINIMUM 18" FROM THE EXISTING BUILDING FOUNDATION UNLESS OTHERWISE INDICATED.
13. ALL UTILITIES TO BE INSTALLED AT A MINIMUM 18" FROM THE EXISTING BUILDING FOUNDATION UNLESS OTHERWISE INDICATED.
14. ALL UTILITIES TO BE INSTALLED AT A MINIMUM 18" FROM THE EXISTING BUILDING FOUNDATION UNLESS OTHERWISE INDICATED.
15. ALL UTILITIES TO BE INSTALLED AT A MINIMUM 18" FROM THE EXISTING BUILDING FOUNDATION UNLESS OTHERWISE INDICATED.
16. ALL UTILITIES TO BE INSTALLED AT A MINIMUM 18" FROM THE EXISTING BUILDING FOUNDATION UNLESS OTHERWISE INDICATED.
17. ALL UTILITIES TO BE INSTALLED AT A MINIMUM 18" FROM THE EXISTING BUILDING FOUNDATION UNLESS OTHERWISE INDICATED.
18. ALL UTILITIES TO BE INSTALLED AT A MINIMUM 18" FROM THE EXISTING BUILDING FOUNDATION UNLESS OTHERWISE INDICATED.
19. ALL UTILITIES TO BE INSTALLED AT A MINIMUM 18" FROM THE EXISTING BUILDING FOUNDATION UNLESS OTHERWISE INDICATED.
20. ALL UTILITIES TO BE INSTALLED AT A MINIMUM 18" FROM THE EXISTING BUILDING FOUNDATION UNLESS OTHERWISE INDICATED.

UTILITY NOTES

1. ALL UTILITIES TO BE INSTALLED AS SHOWN ON THESE PLANS UNLESS INDICATED OTHERWISE.
2. ALL UTILITIES TO BE INSTALLED AS SHOWN ON THESE PLANS UNLESS INDICATED OTHERWISE.
3. ALL UTILITIES TO BE INSTALLED AS SHOWN ON THESE PLANS UNLESS INDICATED OTHERWISE.
4. ALL UTILITIES TO BE INSTALLED AS SHOWN ON THESE PLANS UNLESS INDICATED OTHERWISE.
5. ALL UTILITIES TO BE INSTALLED AS SHOWN ON THESE PLANS UNLESS INDICATED OTHERWISE.
6. ALL UTILITIES TO BE INSTALLED AS SHOWN ON THESE PLANS UNLESS INDICATED OTHERWISE.
7. ALL UTILITIES TO BE INSTALLED AS SHOWN ON THESE PLANS UNLESS INDICATED OTHERWISE.
8. ALL UTILITIES TO BE INSTALLED AS SHOWN ON THESE PLANS UNLESS INDICATED OTHERWISE.
9. ALL UTILITIES TO BE INSTALLED AS SHOWN ON THESE PLANS UNLESS INDICATED OTHERWISE.
10. ALL UTILITIES TO BE INSTALLED AS SHOWN ON THESE PLANS UNLESS INDICATED OTHERWISE.
11. ALL UTILITIES TO BE INSTALLED AS SHOWN ON THESE PLANS UNLESS INDICATED OTHERWISE.
12. ALL UTILITIES TO BE INSTALLED AS SHOWN ON THESE PLANS UNLESS INDICATED OTHERWISE.
13. ALL UTILITIES TO BE INSTALLED AS SHOWN ON THESE PLANS UNLESS INDICATED OTHERWISE.
14. ALL UTILITIES TO BE INSTALLED AS SHOWN ON THESE PLANS UNLESS INDICATED OTHERWISE.
15. ALL UTILITIES TO BE INSTALLED AS SHOWN ON THESE PLANS UNLESS INDICATED OTHERWISE.
16. ALL UTILITIES TO BE INSTALLED AS SHOWN ON THESE PLANS UNLESS INDICATED OTHERWISE.
17. ALL UTILITIES TO BE INSTALLED AS SHOWN ON THESE PLANS UNLESS INDICATED OTHERWISE.
18. ALL UTILITIES TO BE INSTALLED AS SHOWN ON THESE PLANS UNLESS INDICATED OTHERWISE.
19. ALL UTILITIES TO BE INSTALLED AS SHOWN ON THESE PLANS UNLESS INDICATED OTHERWISE.
20. ALL UTILITIES TO BE INSTALLED AS SHOWN ON THESE PLANS UNLESS INDICATED OTHERWISE.



Prepared by: MEYER & ALLEN ARCHITECTS, INC.
 Checked by: [Signature]
 Date: [Date]

NO.	REVISION
1	ISSUED FOR PERMITTING
2	REVISED PER CITY COMMENTS
3	REVISED PER CITY COMMENTS
4	REVISED PER CITY COMMENTS
5	REVISED PER CITY COMMENTS
6	REVISED PER CITY COMMENTS
7	REVISED PER CITY COMMENTS
8	REVISED PER CITY COMMENTS
9	REVISED PER CITY COMMENTS
10	REVISED PER CITY COMMENTS
11	REVISED PER CITY COMMENTS
12	REVISED PER CITY COMMENTS
13	REVISED PER CITY COMMENTS
14	REVISED PER CITY COMMENTS
15	REVISED PER CITY COMMENTS
16	REVISED PER CITY COMMENTS
17	REVISED PER CITY COMMENTS
18	REVISED PER CITY COMMENTS
19	REVISED PER CITY COMMENTS
20	REVISED PER CITY COMMENTS

COSTA MESA POLICE FACILITY
 Expansion & Renovation
 City of Costa Mesa
 17400 Drive
 Costa Mesa, CA 92626

Drawn by: [Signature]
 Checked by: [Signature]
 Date: [Date]

UTILITY PLAN
 1-001
C2.0
 OF 5-12-15

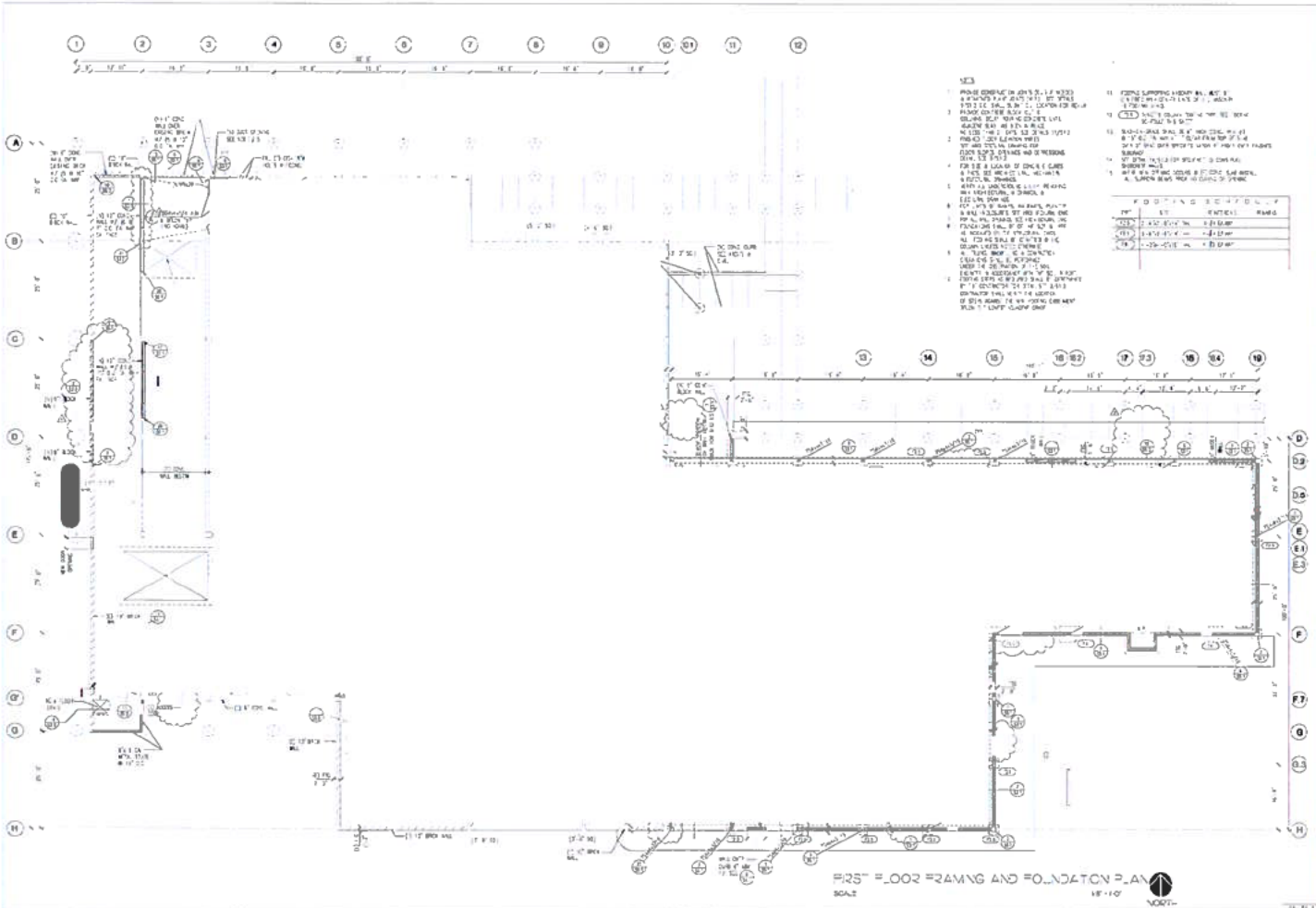

- NOTES**
1. FOUNDATION SHALL BE 12" WIDE CONCRETE FOOTING ON 4" SAND. ALL FOUNDATION SHALL BE 12" WIDE CONCRETE FOOTING ON 4" SAND.
 2. ALL FOUNDATION SHALL BE 12" WIDE CONCRETE FOOTING ON 4" SAND.
 3. ALL FOUNDATION SHALL BE 12" WIDE CONCRETE FOOTING ON 4" SAND.
 4. ALL FOUNDATION SHALL BE 12" WIDE CONCRETE FOOTING ON 4" SAND.
 5. ALL FOUNDATION SHALL BE 12" WIDE CONCRETE FOOTING ON 4" SAND.
 6. ALL FOUNDATION SHALL BE 12" WIDE CONCRETE FOOTING ON 4" SAND.
 7. ALL FOUNDATION SHALL BE 12" WIDE CONCRETE FOOTING ON 4" SAND.
 8. ALL FOUNDATION SHALL BE 12" WIDE CONCRETE FOOTING ON 4" SAND.
 9. ALL FOUNDATION SHALL BE 12" WIDE CONCRETE FOOTING ON 4" SAND.
 10. ALL FOUNDATION SHALL BE 12" WIDE CONCRETE FOOTING ON 4" SAND.
 11. ALL FOUNDATION SHALL BE 12" WIDE CONCRETE FOOTING ON 4" SAND.
 12. ALL FOUNDATION SHALL BE 12" WIDE CONCRETE FOOTING ON 4" SAND.

NO.	DESCRIPTION	DATE
1	FOUNDATION	11/11/11
2	FOUNDATION	11/11/11
3	FOUNDATION	11/11/11
4	FOUNDATION	11/11/11
5	FOUNDATION	11/11/11
6	FOUNDATION	11/11/11
7	FOUNDATION	11/11/11
8	FOUNDATION	11/11/11
9	FOUNDATION	11/11/11
10	FOUNDATION	11/11/11
11	FOUNDATION	11/11/11
12	FOUNDATION	11/11/11

APPROVED BY

REVISIONS

NO.	DESCRIPTION	DATE
1	FOUNDATION	11/11/11
2	FOUNDATION	11/11/11
3	FOUNDATION	11/11/11
4	FOUNDATION	11/11/11
5	FOUNDATION	11/11/11
6	FOUNDATION	11/11/11
7	FOUNDATION	11/11/11
8	FOUNDATION	11/11/11
9	FOUNDATION	11/11/11
10	FOUNDATION	11/11/11
11	FOUNDATION	11/11/11
12	FOUNDATION	11/11/11

COSTA MESA POLICE FACILITY Expansion & Renovation
 City of Costa Mesa
 19 Fair Drive
 Costa Mesa, CA 92626

DESIGNER: DAVID J. SMITH
 LICENSE NO. 10000
 DATE: 11/11/11

PROJECT NO. 11-11-11

FIRST FLOOR FRAMING AND FOUNDATION PLAN

S2.2

DATE: 11/11/11

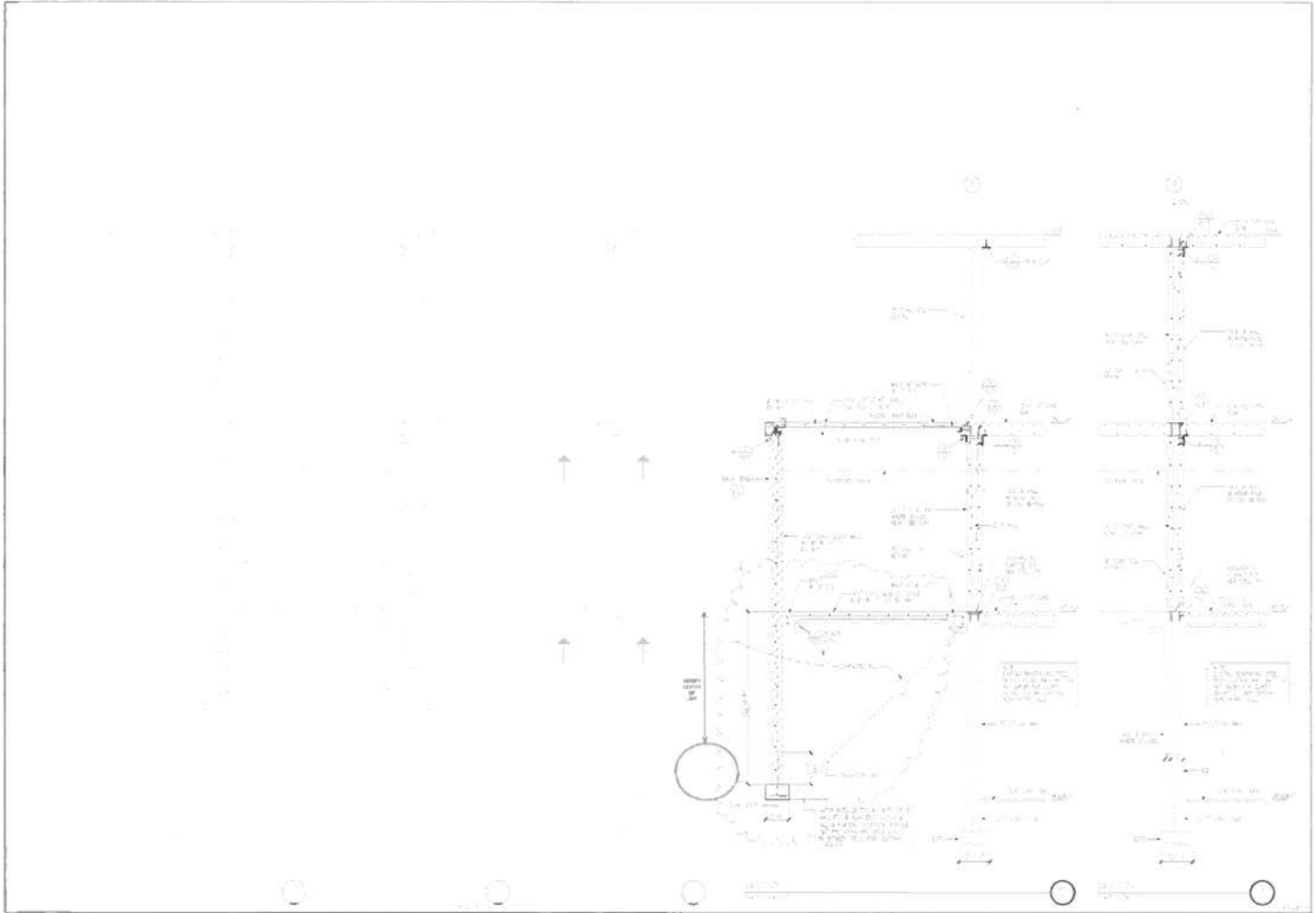

COSTA MESA
POLICE FACILITY
 EXPANSION & RENOVATION
 City of Costa Mesa
 1100 City Center
 Costa Mesa, CA 92626

SECTION

SECTION

SECTION G
[MISCELLANEOUS CONTRACT DOCUMENTS
(SAMPLES) INTENTIONALLY OMITTED]

EXHIBIT C

BONDS

EXHIBIT D

DRUG-FREE WORKPLACE POLICY

CITY OF COSTA MESA, CALIFORNIA

COUNCIL POLICY

SUBJECT	POLICY NUMBER	EFFECTIVE DATE	PAGE
DRUG-FREE WORKPLACE	100-5	8-8-89	1 of 3

BACKGROUND

Under the Federal Drug-Free Workplace Act of 1988, passed as part of omnibus drug legislation enacted November 18, 1988, contractors and grantees of Federal funds must certify that they will provide drug-free workplaces. At the present time, the City of Costa Mesa, as a sub-grantee of Federal funds under a variety of programs, is required to abide by this Act. The City Council has expressed its support of the national effort to eradicate drug abuse through the creation of a Substance Abuse Committee, institution of a City-wide D.A.R.E. program in all local schools and other activities in support of a drug-free community. This policy is intended to extend that effort to contractors and grantees of the City of Costa Mesa in the elimination of dangerous drugs in the workplace.

PURPOSE

It is the purpose of this Policy to:

1. Clearly state the City of Costa Mesa's commitment to a drug-free society.
2. Set forth guidelines to ensure that public, private, and nonprofit organizations receiving funds from the City of Costa Mesa share the commitment to a drug-free workplace.

POLICY

The City Manager, under direction by the City Council, shall take the necessary steps to see that the following provisions are included in all contracts and agreements entered into by the City of Costa Mesa involving the disbursement of funds.

1. Contractor or Sub-grantee hereby certifies that it will provide a drug-free workplace by:
 - A. Publishing a statement notifying employees that the unlawful manufacture, distribution, dispensing, possession, or use of a controlled substance is prohibited in Contractor's and/or sub-grantee's workplace, specifically the job site or location included in this contract, and specifying the actions that will be taken against the employees for violation of such prohibition;
 - B. Establishing a Drug-Free Awareness Program to inform employees about:

SUBJECT	POLICY NUMBER	EFFECTIVE DATE	PAGE
DRUG-FREE WORKPLACE	100-5	8-8-89	2 of 3

1. The dangers of drug abuse in the workplace;
 2. Contractor's and/or sub-grantee's policy of maintaining a drug-free workplace;
 3. Any available drug counseling, rehabilitation and employee assistance programs; and
 4. The penalties that may be imposed upon employees for drug abuse violations occurring in the workplace;
- C. Making it a requirement that each employee to be engaged in the performance of the contract be given a copy of the statement required by subparagraph A;
- D. Notifying the employee in the statement required by subparagraph 1 A that, as a condition of employment under the contract, the employee will:
1. Abide by the terms of the statement; and
 2. Notify the employer of any criminal drug statute conviction for a violation occurring in the workplace no later than five (5) days after such conviction;
- E. Notifying the City of Costa Mesa within ten (10) days after receiving notice under subparagraph 1 D 2 from an employee or otherwise receiving the actual notice of such conviction;
- F. Taking one of the following actions within thirty (30) days of receiving notice under subparagraph 1 D 2 with respect to an employee who is so convicted:
1. Taking appropriate personnel action against such an employee, up to and including termination; or
 2. Requiring such employee to participate satisfactorily in a drug abuse assistance or rehabilitation program approved for such purposes by a Federal, State, or local health agency, law enforcement, or other appropriate agency;

SUBJECT	POLICY NUMBER	EFFECTIVE DATE	PAGE
DRUG-FREE WORKPLACE	100-5	8-8-89	3 of 3

- G. Making a good faith effort to maintain a drug-free workplace through implementation of subparagraphs 1 A through 1 F, inclusive.
2. Contractor and/or sub-grantee shall be deemed to be in violation of this Policy if the City of Costa Mesa determines that:
 - a. Contractor and/or sub-grantee has made a false certification under paragraph 1 above;
 - b. Contractor and/or sub-grantee has violated the certification by failing to carry out the requirements of subparagraphs 1 A through 1 G above;
 - c. Such number of employees of Contractor and/or sub-grantee have been convicted of violations of criminal drug statutes for violations occurring in the workplace as to indicate that the contractor and/or sub-grantee has failed to make a good faith effort to provide a drug-free workplace.
 3. Should any contractor and/or sub-grantee be deemed to be in violation of this Policy pursuant to the provisions of 2 A, B, and C, a suspension, termination or debarment proceeding subject to applicable Federal, State, and local laws shall be conducted. Upon issuance of any final decision under this section requiring debarment of a contractor and/or sub-grantee, the contractor and/or sub-grantee shall be ineligible for award of any contract, agreement or grant from the City of Costa Mesa for a period specified in the decision, not to exceed five (5) years. Upon issuance of any final decision recommending against debarment of the contractor and/or sub-grantee, the contractor and/or sub-grantee shall be eligible for compensation as provided by law.